

(12) INTERNATIONAL APPLICATION PUBLISHED UNDER THE PATENT COOPERATION TREATY (PCT)

(19) World Intellectual Property Organization
International Bureau



(43) International Publication Date
26 June 2003 (26.06.2003)

PCT

(10) International Publication Number
WO 03/051210 A2

- (51) International Patent Classification⁷: A61B 17/58, A61F 2/38
- (21) International Application Number: PCT/US02/40310
- (22) International Filing Date:
17 December 2002 (17.12.2002)
- (25) Filing Language: English
- (26) Publication Language: English
- (30) Priority Data:
10/024,077 17 December 2001 (17.12.2001) US
10/162,533 4 June 2002 (04.06.2002) US
- (71) Applicant: ARTHROSURFACE, INCORPORATED
[US/US]; 1063 Turnpike Street, Stoughton, MA 02072 (US).
- (72) Inventors: EK, Steven, W.; 49 Powder Hill Road, Bolton, MA 01740 (US). TALLARIDA, Steven, J.; 11 Victoria Lane, Mansfield, MA 02048 (US).
- (74) Agents: PFLEGER, Edmund, P. et al.; Grossman Tucker Perreault & Pflieger, PLLC, 55 South Commercial Street, Manchester, NH 03101 (US).
- (81) Designated States (*national*): AE, AG, AL, AM, AT, AU, AZ, BA, BB, BG, BR, BY, BZ, CA, CH, CN, CO, CR, CU, CZ, DE, DK, DM, DZ, EC, EE, ES, FI, GB, GD, GE, GH, GM, HR, HU, ID, IL, IN, IS, JP, KE, KG, KP, KR, KZ, LC, LK, LR, LS, LT, LU, LV, MA, MD, MG, MK, MN, MW, MX, MZ, NO, NZ, OM, PH, PL, PT, RO, RU, SC, SD, SE, SG, SK, SL, TJ, TM, TN, TR, TT, TZ, UA, UG, UZ, VC, VN, YU, ZA, ZM, ZW.
- (84) Designated States (*regional*): ARIPO patent (GH, GM, KE, LS, MW, MZ, SD, SL, SZ, TZ, UG, ZM, ZW), Eurasian patent (AM, AZ, BY, KG, KZ, MD, RU, TJ, TM), European patent (AT, BE, BG, CH, CY, CZ, DE, DK, EE, ES, FI, FR, GB, GR, IE, IT, LU, MC, NL, PT, SE, SI, SK, TR), OAPI patent (BF, BJ, CF, CG, CI, CM, GA, GN, GQ, GW, ML, MR, NE, SN, TD, TG).

[Continued on next page]

(54) Title: SYSTEM AND METHOD FOR JOINT RESURFACE REPAIR

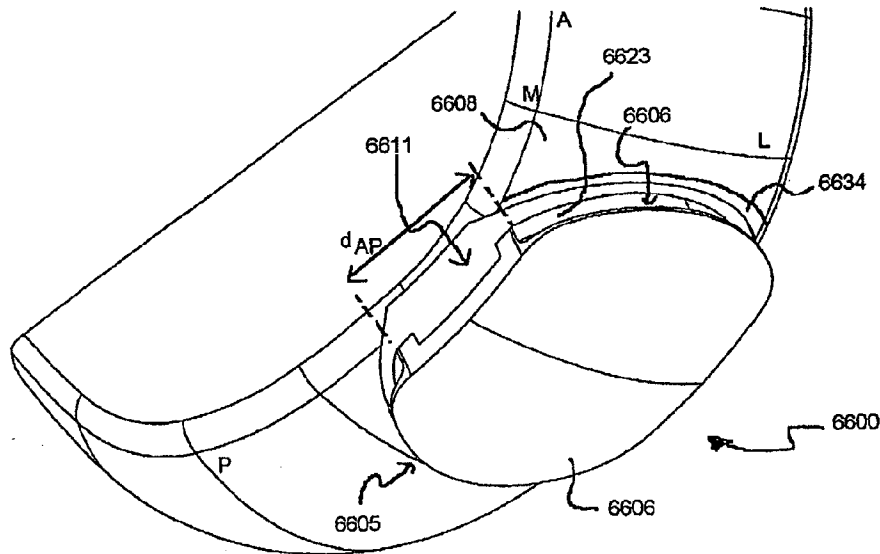

(57) Abstract: An implant for installation into a portion of an articular surface includes a protrusion configured to cover and un-excised portion of articular surface proximate to the implant. Another implant may form a cavity to allow the un-excised portion of articular surface to remodel over a perimeter edge of the implant. The implant may also include indentations such as grooves to promote articular cartilage remodeling over a portion of the load bearing surface of the implant. An elongated or non-round implant is also provided having two opposing concentric arcuate shaped sides, as well as a method to seat such an implant in an articular surface. A method for seating an implant without cutting articular cartilage is also provided.

WO 03/051210 A2

WO 03/051210 A2



Published:

— without international search report and to be republished upon receipt of that report

For two-letter codes and other abbreviations, refer to the "Guidance Notes on Codes and Abbreviations" appearing at the beginning of each regular issue of the PCT Gazette.

SYSTEM AND METHOD FOR JOINT RESURFACE REPAIR

This application is a continuation-in-part application of application Serial No. 10/024,077, filed December 17, 2001, which is itself a CIP application of application Serial No. 09/846,657, filed May 1, 2001, which claims priority from U.S. provisional application Serial No. 60/201,049, filed May 1, 2000, all of which are incorporated herein for reference.

FIELD OF THE INVENTION

This invention relates to devices and methods for the repair of defects that occur in articular cartilage on the surface of bones, particularly the knee.

BACKGROUND OF THE INVENTION

Articular cartilage, found at the ends of articulating bone in the body, is typically composed of hyaline cartilage, which has many unique properties that allow it to function effectively as a smooth and lubricious load-bearing surface. However, when injured, hyaline cartilage cells are not typically replaced by new hyaline cartilage cells. Healing is dependent upon the occurrence of bleeding from the underlying bone and formation of scar or reparative cartilage called fibrocartilage. While similar, fibrocartilage does not possess the same unique aspects of native hyaline cartilage and tends to be far less durable.

Hyaline cartilage problems, particularly in knee and hip joints, are generally caused by disease such as occurs with rheumatoid arthritis or wear and tear (osteoarthritis), or secondary to an injury, either acute (sudden), or recurrent and chronic (ongoing). Such cartilage disease or deterioration can compromise the articular surface causing pain and further deterioration of joint function. As a result, various methods have been developed to treat and repair damaged or destroyed articular cartilage.

For smaller defects, traditional options for this type of problem include non-operative therapies (e.g., oral medication or medication by injection into the joint), or performing a surgical procedure called abrasion arthroplasty or abrasion chondralplasty. The principle behind this procedure is to attempt to stimulate natural healing. At the defect site, the bone surface is abraded, removing approximately 1 mm. or less using a high-speed rotary burr or shaving device. This creates an exposed subchondral bone bed that will bleed and will initiate a fibrocartilage healing response. Although this procedure has been widely used over the past two decades and can provide good short term results, (1-3 years), the resulting fibrocartilage surface

is seldom able to support long-term weight bearing, particularly in high-activity patients, and is prone to wear.

Another procedure, referred to as the "microfracture" technique, incorporates similar concepts of creating exposed subchondral bone. During the procedure, the cartilage layer of the chondral defect is removed. Several pathways or "microfractures" are created to the subchondral bleeding bone bed by impacting a metal pick or surgical awl at a minimum number of locations within the lesion. By establishing bleeding in the lesion and by creating a pathway to the subchondral bone, a fibrocartilage healing response is initiated, forming a replacement surface. Results for this technique are generally similar to abrasion chondralplasty.

Another known option to treat damaged articular cartilage is a cartilage transplant, referred to as a Mosaicplasty or osteoarticular transfer system (OATS) technique. This involves using a series of dowel cutting instruments to harvest a plug of articular cartilage and subchondral bone from a donor site, which can then be implanted into a core made into the defect site. By repeating this process, transferring a series of plugs, and by placing them in close proximity to one another, in mosaic-like fashion, a new grafted hyaline cartilage surface can be established. The result is a hyaline-like surface interposed with a fibrocartilage healing response between each graft.

This procedure is technically difficult, as all grafts must be taken with the axis of the harvesting coring drill being kept perpendicular to the articular surface at the point of harvest. Also, all graft placement sites must be drilled with the axis of a similar coring tool being kept perpendicular to the articular surface at the point of implantation. Further, all grafts must be placed so that the articular surface portion of these cartilage and bone plugs is delivered to the implantation site and seated at the same level as the surrounding articular surface. If these plugs are not properly placed in relation to the surrounding articular surface, the procedure can have a very detrimental effect on the mating articular surface. If the plugs are placed too far below the level of the surrounding articular surface, no benefit from the procedure will be gained. Further, based on the requirement of perpendicularity on all harvesting and placement sites, the procedure requires many access and approach angles that typically require an open field surgical procedure. Finally, this procedure requires a lengthy post-operative non-weight bearing course.

Transplantation of previously harvested hyaline cartilage cells from the same patient has been utilized in recent years. After the cartilage is removed or harvested, it is cultured in the lab to obtain an increase in the number of cells. These cells are later injected back into the focal defect site and retained by sewing a patch of periosteal tissue over the top of the defect to contain the cells while they heal and mature. The disadvantages of this procedure are its enormous expense, technical complexity, and the need for an open knee surgery. Further, this technique is still considered somewhat experimental and long-term results are unknown. Some early studies have concluded that this approach offers no significant improvement in outcomes over traditional abrasion and microfracture techniques.

U.S. Patent No. 5,782,835 to Hart et al. discloses an apparatus and method for repair of articular cartilage including a bone plug removal tool, and a bone plug emplacement tool. The method of repairing defective articular cartilage includes the steps of removing the defective cartilage and forming a hole of sufficient depth at the site. A bone plug comprising intact bone and cartilage adhering thereto is removed from a bone lacking defective cartilage is placed in the hole at the site of the damage.

U.S. Patent No. 5,413,608 to Keller discloses a knee joint endoprosthesis for replacing the articular surfaces of the tibia comprising a bearing part which is anchored on the bone having an upper bearing surface and a rotatable plateau secured on the bearing surface and forming a part of the articular surface to be replaced. A journal rises from the bearing surface and cooperates with a bore in the plateau to provide lateral support.

U.S. Patent No. 5,632,745 to Schwartz describes a method of surgically implanting into a site a bio-absorbable cartilage repair assembly. The assembly includes a bio-absorbable polygonal T-shaped delivery unit having radial ribs to be mounted in the removed area and a porous bio-absorbable insert supported by and in the delivery unit. The method comprises the steps of preparing the site to receive the assembly by removing a portion of the damaged cartilage and preparing the site to receive the assembly by drilling and countersinking the bone. The assembly is inserted and seated using an impactor in the drilled and countersunk hole in the bone until the assembly is flush with the surrounding articular surface.

U.S. Patent No. 5,683,466 to Vitale illustrates an articular joint surface replacement system having two opposing components. Each component has a tapered head piece for covering the end of a bone and for acting as an articular surface, an integrally formed screw stem

of sufficient length to extend into the bone and inwardly angled bone grips on the underside of the head piece to allow fixation to the bone by compression fit. The partially spherical convex shaped exterior of the first component complements the partially spherical concave shaped exterior of the second component.

U.S. Patent No. 5,702,401 to Shaffer discloses an intra-articular measuring device including a hollow handle defining a first passageway and a hollow tube having a second passageway extending from the handle, the hollow tube carrying a projection at its distal end for seating on a fixed site and a probe disposed at the distal end of the hollow tube which may be directed to a second site, to enable measurement of the distance between the first and second sites.

U.S. Patent No. 5,771,310 to Vannah describes a method of mapping the three-dimensional topography of the surface of an object by generating digital data points at a plurality of sample points on said surface, each digital data point including a property value and a position value corresponding to a particular point representing the properties of the surface of the object. A 3-D transducer probe (e.g., a digitizer) is moved on or over the surface along a random path, and the sample points are digitized to generate a real-time topography or map on a computer screen of selected properties of the object, including without limitation, surface elevation, indentation stiffness, elevation of sub-surface layers and temperature.

Prosthetics for total knee replacement (TKR), whereby the entire knee joint or a single compartment of the knee joint is replaced can be a common eventuality for the patient with a large focal defect. Although these patients are also managed with anti-inflammatory medications, eventual erosion of the remaining articular cartilage results in effusion, pain, and loss of mobility and/or activity for the patient. Problems encountered after implanting such prostheses are usually caused by the eventual loosening of the prosthetic due to osteolysis, wear, or deterioration of the cements used to attach the device to the host bones. Further, some prostheses used are actually much larger than the degenerated tissue that needs to be replaced, so that extensive portions of healthy bone are typically removed to accommodate the prostheses. Patients who undergo TKR often face a long and difficult rehabilitation period, and the life span of the TKR is accepted to be approximately 20 years. Accordingly, efforts are made to forgo the TKR procedure for as long as possible.

Accordingly, there is a need for an improved joint surface replacement system that would be effective in restoring a smooth and continuous articular surface and that would also be as durable as the former hyaline cartilage surface, within the context of a minimally invasive procedure that allows for a nearly immediate return to activity, restoration of lifestyle, and pain relief.

SUMMARY OF THE INVENTION

An implant consistent with the invention for installation into a portion of an articular surface includes: a bone-facing distal surface; a proximal surface; and a protrusion formed by an extension of the bone-facing distal surface and the proximal surface.

Another implant consistent with the invention for installation into a portion of an articular surface includes: a bone-facing distal surface configured to mate with an implant site created by excising a portion of the articular surface; a proximal surface having a contour based on an original surface contour of the excised portion of the articular surface; and a cavity configured to allow an un-excised portion of the articular surface proximate to the implant to remodel over a perimeter edge of the proximal surface.

Another implant consistent with the invention for installation into a portion of an articular surface having an anterior portion, a posterior portion, a medial portion and a lateral portion includes: a bone-facing distal surface configured to mate with an implant site created by excising a portion of the articular surface; and a proximal surface having a contour based on an original surface contour of the excised portion of the articular surface, and at least two side surfaces each having a concentric arcuate shape with a common center, wherein the implant has an elongate arcuate geometric shape.

A method for replacing a portion of an articular surface of bone consistent with the invention includes: establishing a working axis substantially normal to an articular surface of bone; excising a portion of the articular surface adjacent to the axis, thereby creating an implant site, the implant site having a first and second opposing arcuate shaped sides; and installing an implant to the implant site.

Another method of replacing a portion of an articular surface of bone consistent with the invention includes: locating an existing defect in the articular surface; establishing a working axis substantially normal to the articular surface and substantially centered with the existing defect; excising a portion of the articular surface adjacent to the axis, thereby creating an implant

site; and installing an implant in the implant site, wherein at least a portion of the existing defect is exposed around a perimeter of the implant.

Another implant for installation into a portion of an articular surface consistent with the invention includes: a bone-facing distal surface configured to mate with an implant site created by excising a portion of the articular surface; a proximal surface having a contour based on an original surface contour of the excised portion of the articular surface; at least one arcuate shaped side surface configured to abut an edge of the excised portion of the articular surface, the arcuate shaped side surface having a radial extension configured to cover an un-excised portion of the articular surface proximate to the implant.

Another method for replacing a portion of an articular surface of bone consistent with the invention includes: establishing a working axis substantially normal to an articular surface of bone, the articular surface having a medial side and lateral side defining a width of the articular surface; excising a portion of the articular surface adjacent to the axis, thereby creating an implant site, wherein the excising is performed using a cutting tool that rotates about the axis, the cutting tool having a circular blade portion, the circular blade portion having a diameter greater than the width of the articular surface; and installing an implant to the implant site.

Another implant consistent with the invention for installation into a portion of an articular surface includes: a bone-facing distal surface configured to mate with an implant site created by excising a portion of the articular surface; and a proximal surface having a contour based on an original surface contour of the excised portion of the articular surface, wherein the proximal surface has at least one indentation formed in the proximal surface configured to promote remodeling of articular cartilage over a portion of the proximal surface of the implant once seated.

DESCRIPTION OF THE DRAWINGS

Figure 1 is a fragmentary side view of a knee having therein an exemplary assembled fixation device and implant of the joint surface repair system surgically implanted by the method in one embodiment of the present invention;

Figure 2a is an exploded side view of an exemplary fixation screw and hex-shaped proximal extension in one embodiment of the present invention;

Figure 2b is an exploded perspective view of an exemplary fixation screw and hex-shaped proximal extension in one embodiment of the present invention;

Figure 3a is a side view of an exemplary assembled fixation screw and hex shaped extension in one embodiment of the present invention;

Figure 3b is an exploded perspective view of another exemplary fixation screw and implant in one embodiment of the present invention;

Figure 4a is a perspective view of the upper surface of an exemplary implant in one embodiment of the present invention;

Figure 4b is a side view of an exemplary implant in one embodiment of the present invention;

Figure 4c is a perspective view of the lower surface of an exemplary implant in one embodiment of the present invention;

Figure 5a is a side view of an exemplary assembled fixation device and implant in one embodiment of the present invention;

Figure 5b is a perspective view of an assembled fixation device and implant in one embodiment of the present invention;

Figure 5c is a perspective view of the upper surface of an exemplary implant, in one embodiment of the present invention;

Figure 5d is a perspective view of the lower surface of an exemplary implant, in one embodiment of the present invention;

Figure 6a is a sectional view of a knee having damaged articular cartilage, showing an exemplary guide pin drilled into the central portion of the defect and an arthroscope being disposed adjacent thereto, in a surgical procedure consistent with one embodiment of the present invention;

Figure 6b is a side view of the distal tip of an exemplary drill device for boring a pilot hole to receive an exemplary fixation screw, in one embodiment of the present invention;

Figure 7a is a sectional view of a knee having damaged articular cartilage, showing an exemplary fixation screw being driven into the defect by an exemplary socket type driver

arranged on the guide pin, in a surgical procedure consistent with one embodiment of the present invention;

Figure 7b is a side view of the exemplary fixation screw, socket type driver and guide pin of Figure 7a, illustrating the hex shaped proximal extension in a cross-sectional view, in a surgical procedure consistent with one embodiment of the present invention;

Figure 8a is a perspective view of a knee having damaged articular cartilage, showing an exemplary fixation screw and hex-shaped proximal extension implanted in the defect after removal of an exemplary socket type driver and guide pin, in a surgical procedure consistent with one embodiment of the present invention;

Figure 8b is a sagittal view of the exemplary fixation screw and hex-shaped proximal extension of Figure 8a implanted in the defect after removal of an exemplary socket type driver and guide pin, in a surgical procedure consistent with one embodiment of the present invention;

Figure 8c is a perspective view of an exemplary fixation screw, proximal extension and cover, in one embodiment of the present invention;

Figure 9a is a sectional view of an exemplary fixation screw and hex-shaped proximal extension implanted in the defect with the exemplary guide pin replaced and an exemplary measuring tool arranged thereon, in a surgical procedure consistent with one embodiment of the present invention;

Figure 9b is a side partial cross-sectional view of the exemplary fixation screw and hex-shaped proximal extension of Figure 9a implanted in the defect with the exemplary guide pin replaced and an exemplary measuring tool arranged thereon, in a surgical procedure consistent with one embodiment of the present invention;

Figure 9c is a perspective view of an exemplary fixation screw and proximal extension, with the cover removed, in one embodiment of the present invention;

Figure 10a is a sectional view of an exemplary fixation screw and hex-shaped proximal extension implanted in the defect, after removal of the hex-shaped proximal extension, with an exemplary pin and suture strands placed therethrough, in a surgical procedure consistent with one embodiment of the present invention;

Figure 10b is a side partial cross-sectional view of the exemplary fixation screw and hex-shaped proximal extension of Figure 10a, implanted in the defect, with an exemplary pin and suture strands placed therethrough, in a surgical procedure consistent with one embodiment of the present invention;

Figure 11a is a sectional view of an exemplary fixation screw implanted in the defect, with an exemplary pin and suture strands placed therethrough, showing the implanted fixation screw with the implant being tensioned on the suture strands, in a surgical procedure consistent with one embodiment of the present invention;

Figure 11b is a partial cross-sectional view of the exemplary fixation screw of Figure 9a implanted in the defect, showing the implant positioned in the interchondular notch, in a surgical procedure consistent with one embodiment of the present invention;

Figure 12 is a sectional view of an exemplary fixation screw implanted in the defect, wherein, after placement of the implant and removal of the suture strands, the implant is driven into place with an impactor and hammer, in a surgical procedure consistent with one embodiment of the present invention;

Figure 13 is a side cross-sectional view of an exemplary fixation screw implanted in the defect, after placement of the implant, wherein, after removal of the impactor and hammer, cement is injected between the implant and the bone, in a surgical procedure consistent with one embodiment of the present invention;

Figure 14a is a schematic representation of the two datum curves used to define a patient-specific three-dimensional surface for construction of the articular or lower surface of an implant in one embodiment of the present invention;

Figure 14b is a top view of an exemplary hex-shaped proximal extension in one embodiment of the present invention;

Figure 14c is a perspective view of the bone-contacting or upper surface of an exemplary implant, in one embodiment of the present invention;

Figure 15a is a perspective view of an exemplary compass instrument, in one embodiment of the present invention;

Figure 15b is a perspective view of the distal offset arm of an exemplary compass instrument and cutting blade to be mounted thereon, in one embodiment of the present invention;

Figure 15c is a perspective view of an exemplary driver, showing an exemplary implant on an exemplary tether element, in one embodiment of the present invention;

Figure 15d is a perspective view of an exemplary driver, showing an exemplary implant tensioned on an exemplary tether element, in one embodiment of the present invention;

Figure 16 is a perspective view of an exemplary compass instrument and cutting blade mounted on an exemplary guide pin, in one embodiment of the present invention;

Figure 17a is a perspective view of another exemplary cutting blade, in one embodiment of the present invention;

Figure 17b is a perspective view of an exemplary measuring probe, in one embodiment of the present invention;

Figure 17c is a perspective view of an exemplary multi-faced blade mounted in the distal offset arm of an exemplary compass instrument, in one embodiment of the present invention;

Figure 18a is a perspective view of an exemplary site preparation and cutting device, in one embodiment of the present invention;

Figure 18b is a cross sectional view of the exemplary site preparation and cutting device of Figure 18a, in one embodiment of the present invention;

Figure 18c is a perspective view of another exemplary site preparation and cutting device, in one embodiment of the present invention;

Figure 18d is a side view of another exemplary site preparation and cutting device, in one embodiment of the present invention;

Figure 18e is a perspective view of another exemplary site preparation and cutting device, in one embodiment of the present invention;

Figure 19a is a sectional view of the upper surface of an exemplary implant, in one embodiment of the present invention;

Figure 19b is a side view of a portion of the exemplary implant of Figure 19a, in one embodiment of the present invention;

Figure 19c is a perspective view of the upper surface of the exemplary implant of Figure 19a, in one embodiment of the present invention;

Figure 19d is an exploded perspective view of another exemplary implant with taper lock ring, washer and suture, in one embodiment of the present invention;

Figure 19e is a top perspective view of the exemplary implant of Figure 19d seated in the taper lock ring, in one embodiment of the present invention;

Figure 19f is a bottom perspective view of the exemplary implant of Figure 19d seated in the taper lock ring, with washer and suture, disposed within an incision near the defect site, in one embodiment of the present invention;

Figure 19g is a perspective view of the exemplary implant of Figure 19d seated in the taper lock ring, with washer and suture, wherein the suture is threaded through an aperture at the distal end of a seating tool, at a first point in time during the process of seating the implant into the defect site, in one embodiment of the present invention;

Figure 19h is another perspective view of the exemplary implant of Figure 19d seated in the taper lock ring, with washer and suture, wherein the suture is threaded through an aperture at the distal end of a seating tool, at a second point in time during the process of seating the implant into the defect site, in one embodiment of the present invention;

Figure 19i is another perspective view of the exemplary implant of Figure 19d seated in the taper lock ring, wherein the distal end of a seating tool is disposed onto the implant, at a third point in time during the process of seating the implant into the defect site, in one embodiment of the present invention;

Figure 20a is a perspective view of an exemplary inner recording element of an exemplary measuring device, in one embodiment of the present invention;

Figure 20b is a perspective view of an exemplary outer marking element of an exemplary measuring device, in one embodiment of the present invention;

Figure 20c is a cross-sectional perspective view of an exemplary measuring device showing an exemplary inner recording element and an exemplary outer marking element, in one embodiment of the present invention;

Figure 20d is an exploded perspective view of another exemplary measuring device, in one embodiment of the present invention;

Figure 20e is a perspective view of the exemplary measuring device of Figure 20d, illustrating an exemplary scroll alignment feature, in one embodiment of the present invention;

Figures 20f and 20g are side views of the exemplary measuring device of Figure 20d illustrating the translational motion of the handle with respect to the tip of the device, in one embodiment of the present invention;

Figure 20h is a perspective view of the distal end of the exemplary measuring device of Figure 20d, in one embodiment of the present invention;

Figure 20i is a perspective view of the distal end of the exemplary measuring device of Figure 20d with outer element, disposed upon the inner element engaging a mating feature of the screw, in one embodiment of the present invention;

Figure 21 is a perspective view of an exemplary unitary implant, in one embodiment of the present invention;

Figure 22 is a perspective view of a defect site with a keyed aperture for receiving the exemplary unitary implant of Figure 21, in one embodiment of the present invention;

Figure 23 is a perspective view of an exemplary composite implant, in one embodiment of the present invention;

Figure 24 is a perspective view of another exemplary composite implant, in one embodiment of the present invention;

Figure 25 is a perspective view of an exemplary implant illustrating the geometry of said implant for use in an algorithm for establishing minimum implant thickness, in one embodiment of the invention;

Figure 26 is a perspective view of an exemplary implant illustrating the geometry of said implant for use in an algorithm for establishing minimum implant thickness, in one embodiment of the invention;

Figure 27a is a perspective view of an exemplary drill guide device in an exemplary generic bone implant embodiment of the present invention;

Figure 27b is a perspective view of another exemplary drill guide device in an exemplary generic bone implant embodiment of the present invention;

Figure 28a is a top sectional view of the anterior-posterior plane of an articulating surface in an exemplary generic bone implant embodiment of the present invention;

Figure 28b is a side sectional view of the medial-lateral plane of an articulating surface in an exemplary generic bone implant embodiment of the present invention;

Figure 29 is a perspective view of the use of an exemplary drill guide in an exemplary generic bone implant embodiment of the present invention, as the drill guide is brought up to a lesion site of the articulating surface;

Figure 30 is a perspective view of the use of an exemplary drill guide in an exemplary generic bone implant embodiment of the present invention, as the drill guide is seated into position and a guide pin is driven through the drill guide;

Figure 31 is a perspective view of the articulating surface in an exemplary generic bone implant embodiment of the present invention, as a bone drill is passed over the guide pin to create a pilot hole for the screw;

Figure 32 is a cross-sectional view of the articulating surface in an exemplary generic bone implant embodiment of the present invention, as the screw is driven into the pilot hole with a cap positioned into the screw;

Figure 33 is a cross-sectional view of the articulating surface in an exemplary generic bone implant embodiment of the present invention, as the cap is removed and a rod is inserted into the screw, and the guide is positioned back over the rod and returned to its position in contact with the articular surface;

Figure 34 is a side perspective view of the articulating surface in an exemplary generic bone implant embodiment of the present invention, as the guide is used to take a depth measurement needed for implant geometry;

Figure 35 is a top perspective view of the lower surface of an exemplary implant in an exemplary generic bone implant embodiment of the present invention;

Figure 36 is a side perspective view of an exemplary implant in an exemplary generic bone implant embodiment of the present invention;

Figure 37 is a side perspective view of another exemplary implant in an exemplary generic bone implant embodiment of the present invention;

Figure 38 is a perspective view of the articulating surface in an exemplary generic bone implant embodiment of the present invention, as the implant site is reamed with a cutting/reaming tool in preparation for receiving an implant;

Figure 39 is a top perspective view of an alternative exemplary cutting/reaming tool in an exemplary generic bone implant embodiment of the present invention,

Figure 40 is a side perspective view of an exemplary cleaning tool for cleaning the female taper of the screw prior to delivery of the implant, in an exemplary generic bone implant embodiment of the present invention;

Figure 41 is a side perspective view of an exemplary suction tool for holding and delivering the implant, in an exemplary generic bone implant embodiment of the present invention;

Figure 42 is a side perspective view of an exemplary suction tool holding an implant in place, in an exemplary generic bone implant embodiment of the present invention;

Figure 43 is a side cross-sectional view of an exemplary suction tool holding an implant in place, with an implant in place, in an exemplary generic bone implant embodiment of the present invention;

Figure 44 is a top perspective view of the articulating surface in an exemplary generic bone implant embodiment of the present invention, with the implant driven into its final position;

Figure 45 is a side perspective view of an exemplary removal/revision tool in an exemplary generic bone implant embodiment of the present invention;

Figure 46 is a side perspective view of an exemplary removal/revision tool, with an implant in place, in an exemplary generic bone implant embodiment of the present invention;

Figure 47 illustrates an exemplary alternatively-keyed embodiment of the screw and the exemplary alternatively-keyed implant to which it is adapted to mate, in an exemplary embodiment of the present invention;

Figure 48 illustrates a side cross-sectional view of an exemplary alternatively-keyed embodiment of the screw, in an exemplary embodiment of the present invention;

Figure 49 illustrates a side perspective view of the articular surface of a lesion site and an exemplary biaxial measuring tool for developing an axis normal to the articular surface, in one embodiment of the present invention

Figure 50 illustrates another side perspective view of the articular surface of a lesion site and an exemplary biaxial measuring tool for developing an axis normal to the articular surface, in one embodiment of the present invention;

Figure 51 illustrates a side exploded view of an exemplary biaxial measuring tool, in one embodiment of the present invention;

Figure 52 illustrates a top perspective view of the distal end of an exemplary biaxial measuring tool in a first position, in one embodiment of the present invention;

Figure 53 illustrates a top perspective view of the distal end of an exemplary biaxial measuring tool in a second position, in one embodiment of the present invention;

Figure 54 illustrates an exemplary digital measuring system in one embodiment of the present invention;

Figure 55 illustrates an exploded perspective view of an exemplary handpiece in an exemplary digital measuring system in one embodiment of the present invention;

Figure 55a illustrates a top perspective cutaway view of an exemplary printed linear index strip passing through an exemplary linear head for reading, in an exemplary handpiece in an exemplary digital measuring system in one embodiment of the present invention;

Figure 55b illustrates a top perspective cutaway view of an exemplary printed rotary index strip passing through an exemplary rotary head for reading, in an exemplary handpiece in an exemplary digital measuring system in one embodiment of the present invention;

Figure 55c illustrates an exemplary linear index strip in an exemplary handpiece in an exemplary digital measuring system in one embodiment of the present invention;

Figure 55d illustrates an exemplary rotary index strip in an exemplary handpiece in an exemplary digital measuring system in one embodiment of the present invention;

Figure 56a illustrates a side perspective view of an exemplary handpiece with the probe assembly removed, in an exemplary digital measuring system in one embodiment of the present invention;

Figure 56b illustrates a side perspective view of an exemplary handpiece, including the probe assembly, in an exemplary digital measuring system in one embodiment of the present invention;

Figure 57 illustrates a top perspective view of an assembled exemplary handpiece, in an exemplary digital measuring system in one embodiment of the present invention;

Figure 58 illustrates a side perspective view of an assembled exemplary handpiece, in an exemplary digital measuring system in one embodiment of the present invention;

Figure 59 illustrates a top cross-sectional view of an assembled exemplary handpiece, in an exemplary digital measuring system in one embodiment of the present invention;

Figure 60 illustrates a side cross-sectional view of an assembled exemplary handpiece, in an exemplary digital measuring system in one embodiment of the present invention;

Figure 61 illustrates a side cutaway perspective view of an exemplary base unit, in an exemplary digital measuring system in one embodiment of the present invention;

Figure 62A is a top perspective view an alternative exemplary embodiment of a substantially round implant having a protrusion;

Figure 62B is a cross sectional view of the implant of Figure 62A taken along the line B-B of Figure 62A;

Figure 62C is a side perspective view of the implant of Figure 62A;

Figure 63A is a side perspective view of another implant embodiment consistent with the invention having protuberances;

Figure 63B is a cross sectional view of the implant of Figure 63A taken along the line B-B of Figure 63A;

Figure 64A is an alternative embodiment of an implant having a cavity to allow an unexcised portion of articular surface proximate to the implant to grow over the perimeter edge of the implant;

Figure 64B is a cross sectional view of the implant of Figure 64A taken along the line B-B of Figure 64A;

Figure 65A is another alternative embodiment of an elongated implant consistent with the invention;

Figure 65B is a perspective view of an implant site and a reaming tool for preparing the implant site to accept the implant of Figure 65A;

Figure 65C is a cross sectional view of the bottom surface of the implant site of Figure 65B;

Figure 65D is a perspective view of the implant of Figure 65A being seated or placed into the implant site of Figure 65B;

Figure 66A is a top perspective view of alternative elongated implant embodiment having protrusions for covering proximate portions of un-excised articular surface when the implant is seated;

Figure 66B is a top perspective view of the implant of Figure 66A being seated or placed into a matching implant site;

Figure 67 is a perspective view of an implant being seated into an existing defect without cutting the borders of the defect;

Figure 68A is a top perspective view of an implant having grooves to promote remodeling of articular cartilage over a proximal surface of the implant;

Figure 68B is a cross sectional view of the implant of Figure 68A;

Figure 68C is a perspective view of a portion of the perimeter edge of the implant of FIG. 68A illustrating particular edge geometry to also promote remodeling of articular cartilage over a proximal surface of the implant; and

Figure 68D is a top perspective view of the implant of Figure 68A seated in an articular surface illustrating the remodeling of articular cartilage over a portion of the proximal surface of the implant.

DETAILED DESCRIPTION OF THE EMBODIMENTS

As an overview, Figure 1 shows a surgically implanted articular joint surface repair system consistent with the present invention. As shown, the assembled fixation device includes fixation screw 10, implant 40, and anchoring pin 5, implanted in the defect in the medial femoral

chondral surface 55 of knee 50. Implant 40 is configured so that bearing or bottom surface 41 of the implant reproduces the anatomic contours of the surrounding articular surface of the knee 50.

As illustrated in Figures 2a, 2b and 3a, fixation screw 10 comprises threads 12 running the length of the screw from tapered distal tip 11 to hex-shaped drive 15. In the embodiment shown, the screw includes a tapered distal end 11, and aggressive distal threads 12, so that, as screw 10 is driven into the subchondral bone 100 (as shown in Figure 7a) the screw dilates open and radially compresses the subchondral bone, increasing its local density and thereby increasing the fixation strength of the screw. The screw 10 may taper down to the distal end 11, and the diameter of the screw may become greater and more uniform at the center thereof, so that adjustment of the depth of the screw 10 with respect to the subchondral bone 100 does not significantly further increase or decrease the compression of the subchondral bone.

One or more milled slots 13 run the length of the uniform diameter portion of the screw 10. Slots 13 ensure that as healing or tissue in-growth begins, migrational or rotational movement of the screw is inhibited. The screw 10 is configured to be driven by a female or socket type driver 2 as shown in Fig. 7b, which engages a hex-shaped drive 15 located toward the proximal end 17 of the screw. A cylindrical proximal extension 14 (which may, alternatively, be a recess 303 which mates with a plug or other protrusion on the implant surface, as shown in Figure 8c) extends from hex-shaped drive 15, which eventually serves as a fixation element for surface prosthetic implant 40. Through hole 16 runs through the central axis of the screw. Hex-shaped cover 30 (which may, alternatively, be a plug 301, for mating with a fixation element 302 having a recess, as shown, e.g., in Figures 3b, 8c, and 9c, and described in the following paragraph) is configured to engage the cylindrical proximal extension 14 of the screw 10 to prevent exposure of the cylindrical extension from inadvertent contact or damage. The hex-shaped cover 30 is finished with a radiused proximal end 31 that assists in the visual determination of the correct depth setting of the screw. Through hole 32 in the hex-shaped cover 30 corresponds with through hole 16 in the fixation screw 10.

Alternatively, as shown in Figures 3b, 8c, and 9c, the female-shaped cover may instead be a plug 301 having a male-shaped mating component 305, for mating with a fixation element 302 of a screw 10' having a recess 303. Additionally, the shape of the cover and plug, or other recessed, protruding, or mating components may be other than hexagonal, and those in the art

will recognize that one of any number of shapes or configurations for such components may be employed in a device or method consistent with the invention.

Also, while many of the components described herein are cannulated, having guide apertures, through holes, and/or central lumina along their length, for disposing such components about a guide rod for proper location of the components with respect to the articular surface, it should be recognized that a suture 313 or other flexible element, or other guide feature may be used in place of a guide rod, or a guide rod or wire may be eliminated altogether from one or more steps consistent with the invention described herein. As shown in Figure 8c, the suture 313 may be fixedly or removably attached to the plug 301.

As shown in Figures 4a, 4b and 4c, implant 40 comprises lower bearing surface 41, top surface 42 and protrusion 45 located centrally on the bottom surface. As the top surface 42 of the implant 40 is not a bearing surface, and instead is fixed into subchondral bone 100, a series of stepped machine cuts 43 following the contours of the defect are created. By creating stepped machine cuts 43 a contoured contact surface matching the defect in the subchondral bone 100 is created. This contact surface results in an increased surface area that should enhance resistance to loosening of the implant 40 via rotational or translational loading. In the illustrated embodiment, the stepped cuts are shown as square cross-section cuts, but the cuts may be circular, triangular, or another configuration.

In order to secure the implant 40 to the fixation screw 10, precision taper 44 is machined into or onto a protrusion 45 on the top surface 42 of the implant. The precision taper 44 is configured to engage the cylindrical proximal extension 14 of the screw 10, once the hex-shaped cover 30 has been removed therefrom. Taper 44 may be mated with extension 14 so that a friction fit is provided between these surfaces. The assembled fixation device is shown in Figures 5a and 5b. Alternatively, other engagement mechanisms such as snap-fits, press-fits, threads, or coupling elements, for example, may also be used. In one embodiment, leading pin 47 arranged on the protrusion 45 assists penetration into subchondral bone. Also, in one embodiment, guide aperture 46 passes through the top 42 and bottom 41 surfaces of the implant 40, just slightly off center of the reference axis 20A. Alternatively, guide aperture 46 may be located in the center of the implant 40 and corresponds to through hole 16 running through the central lumen in the fixation screw 10. Bone cement may be injected through guide aperture 46

on the surface of the implant 40 and through hole 16 in the fixation screw 10, to enhance the contact surface between the device and the subchondral bone. In one embodiment, the implant is constructed of cobalt chromium, although other materials may be used, including implantable plastics. Additionally, biologically active coatings or surface treatments (e.g., to enhance bone ingrowth or improve wear properties) may be utilized or combined as laminates, particularly with respect to the bearing surfaces and bone contacting surfaces. Further exemplary materials that may be used in fabricating an implant consistent with the invention are described hereinbelow.

As shown in Figure 3b, it is noted that precision taper 44 may be a male-shaped component 304 instead of the above-described female component 44. In this configuration, the male-shaped component 304 of the implant 40' is configured for mating with a fixation element 302 of the screw 10' having a recess 303 adapted to receive the male-shaped component 304.

By way of example, Figures 6a-13 depict one exemplary joint surface methodology of the present invention. Figure 6a shows a focal defect 1 of the articular surface 55 of the femoral chondyle bone of the knee 50. This defect is identified by arthroscope 25 inserted in the area of the defect 1 during a diagnostic arthroscopy or surgical arthroscopy. The disclosed surgical intervention begins by drilling a guide pin 20 defining reference axis 20A into the central portion of the defect 1 via an incision 200 typical of arthroscopic procedures. Placement of this pin may be done using visual, freehand techniques, or may be located centrally by using outer element 71 of a measuring tool 70 (as shown in Figures 9a and 9b), or other aiming device or technique, to define a center. This reference axis 20A serves to establish a working axis located central to the defect 1 for the procedures that follow, and arthroscope 25 may be used to view the joint for purposes of establishing a reference axis 20A generally perpendicular to and bisecting the existing articular surface 55 defined by radii 60 and 61, as shown in Figure 8b. Referring to Figure 7a, 7b, 8a and 8b, fixation screw 10 and hex-shaped cover 30 are driven into the defect 1 in the subchondral bone 100 by socket-type driver 2 mounted over (i.e., about) guide pin 20 located on reference axis 20A. Under arthroscopic view, the depth of fixation screw 10 may be adjusted by driver 2 so that the bottom of the radiused surface 31 of the hex-shaped cover 30 is positioned tangent to the radii 60 and 61 that define the existing articular surface 55. The guide pin 20 is removed and the knee 50 is articulated through its range of motion to ensure that the height of the radiused surface 31 of the hex-shaped cover 30 is proper, since the prosthetic

surface 41 of the implant 40 is created also to be tangent to this radiused surface 31. The depth positioning of the radiused surface 31 of the hex-shaped cover 30 establishes a point of origin or a reference point for all future measuring and machining operations. Arthroscopic examination may be carried out from multiple arthroscopic views to confirm positioning.

A drill mechanism 306, as illustrated in Figure 6b, may be used to bore a pilot hole for receiving a fixation screw 10 (as shown, e.g., in Figures 2a, 2b and 3a). As shown, the drill may have a shank portion 307 and a bit portion 308. The bit portion 308 may include a spiral or parabolic fluted tip 309 having proximal 310, medial 311, and distal 312 portions. The root diameter at the medial portion 311 is substantially equal to the diameter of the fixation screw 10, and the diameter decreases as the distal portion 312 tapers away from the shank 307. The proximal portion 310 of the bit 308 may be used as a visual indicator during drilling, to determine the point at which the proper bore depth has been attained. The drill mechanism may have a central lumen (not shown) having a diameter slightly greater than the diameter of the guide pin 20 (as illustrated in Figure 6a) running along its length, so that, with the guide pin 20 in place, the drill 306 may be disposed about the guide pin 20 during drilling to ensure proper location of the pilot hole with respect to the articular surface 55. Alternatively, a self-drilling or self-tapping screw, may be used, as those skilled in the art will recognize.

For surface preparation and accurate measurement of the implant site and the subsequent sizing of the implant, instrument 120 is provided. The compass instrument 120 may be configured to serve as a mounting tool for a number of functional blades or tips and when located about the axis 20A, via guide rod 20, may be used for measuring and cutting operations. In the embodiment shown in Figure 15a, compass instrument 120 includes handle 110, a cannulated shaft 111 that extends through the handle, and a cannulated distal offset arm 112. The instrument may be rigid in construction and may be a durable reusable and resterilizable instrument. The distal offset arm 112 is configured so that it can be introduced into a site through an incision 200 typical of an arthroscopic procedure. Once the distal offset arm 112 has fully penetrated the incision and enters the site, shaft 111 can be angularly repositioned so that it becomes more coaxial to the reference axis 20A and advanced in-line with the reference axis 20A towards the implant target site. While performing this maneuver to position the compass instrument 120, the guide pin 20 should be removed from its position in the defect 1. When compass 120 is in its proper position at or near the implant target site, the guide pin 20 is

delivered through the instrument cannulation 113, re-establishing the working (reference) axis 20A used to define the implant geometry.

Referring to Figure 15b, within offset arm 112 is a slotted surface 114 for engaging a series of cutting blades 121, boring blades 124, or measuring probes 122. The slots 115 are configured so that said series of cutting blades 121, boring blades 124 (Figure 17c), measuring probes 122, 123 (Figures 17a, 17b), or like elements may be partially constrained or fixed in position such that they may be adjusted linearly along the length of the slotted surface 114 over a defined distance of travel. Intersecting the plane of travel defined by slotted surface 114 and slots 115, is the cannulation 113.

As illustrated in Figure 16, when fitted with a cutting blade 121, and with the guide pin 20 advanced through the shaft 113 of instrument 120, so that the guide pin passes through a closely sized hole 116 in the cutting blade, the blade's position becomes fully constrained. When constrained in this fashion, a fixed length from the rotational or reference axis 20A to the cutting surface 117 of cutting blade 121 is established. This defines the radius that is effected as the instrument 120 is rotated around the guide pin 20, and corresponds to the overall diameter of the implant 40 that is delivered to the fully prepared site. The cutting blade 121 is used to circumscribe and cleanly cut the surrounding articular cartilage.

In an alternative embodiment, as shown in Figures, 17a and 17b, blade 123 and measuring probe 122, respectively, may have multiple holes 118 that defines that probe/blade's functional diameter. In addition, the blades may be specifically configured so that staged or sequential cuts of varying depths and diameters can be performed within the procedure. Also, such a blade can be configured by providing a readable scale 119 corresponding to the hole 118 pattern, so that the surgeon may determine and set the appropriate diameter as needed by positioning the guide pin 20 in the corresponding hole. As the readable scale 119 may be located on the blade 123 with respect to the blade's cutting surface 117, a high degree of positional accuracy may be achieved as the scale may be defined specifically for each type of blade. This approach creates an inexpensive means of providing sharp blades of varying diameters and varying blade types without a large inventory of size- and type-specific blades. Referring to Figure 17b, rounded tip 109 of measuring probe 122 can be used to determine the appropriate diameter and can be similarly sized and secured in the compass instrument 120. The tip 109

may be rounded to prevent marring of the articular surface. Figure 17c shows a boring bit or bone cutting blade 124 with multiple cutting surfaces 107 and 108 configured in this fashion.

Turning now to Figures 9a and 9b, with the guide pin 20 replaced, a measuring tool 70 is inserted so that the reference axis 20A is utilized. A central element of the measuring tool 70 is a post 75 that is static, establishes the axial location of the point of origin 80, and mates with a rotational location feature within the screw 14. By rotating the outer arm or outrigger 71 of the measuring tool 70 relative to the static post 75 while also maintaining contact with the articular surface 55, an axial displacement or Z dimension can be established relative to the point of origin 80 for any point along the sweep of the outrigger. Each such Z dimension may be recorded in real time with conventional dial gauge indicators 72 or with a digital recording device, such as disclosed in U.S. Patent No. 5,771,310 to Vannah, or by using other known marking techniques. Although numerous points may be taken, ideally a minimum number of points are taken to define accurately the target articular surface. In other embodiments, multiple outriggers that embody different diameters or an adjustable outrigger may be used to map larger defects, and also to determine the final diameter of the prosthetic surface that fits within the defect. It is noted that the measuring tool may comprise a spring or other tensioning device (not shown), for urging the outrigger distally with respect to the handle of the tool. In this aspect, the outrigger is manually pressed against the articular cartilage, so as to maximally compress the articular cartilage upon recording data points, so that the data points taken are of a maximally "loaded" or "compressed" dimension.

Figures 20a, 20b and 20c show an alternative measuring and mapping device 210 for obtaining the articular surface dimension, comprising housing 217 and a recording element 218. As shown in Figure 20a, recording element 218 includes upper portion 219, flange 222 and calibrated lower portion 220. Key-shaped surface 221 located at distal end 225 of recording element 218 is configured to engage a reciprocal key-shaped surface in the proximal extension 14 of fixation screw 10, or, for example, a key shaped cover arranged on the proximal end of the screw (not shown). The upper portion 219 of recording element 218 may be constructed of a relatively soft or other deformable material that can be marked with patient data. Cannulated shaft 223 runs through the central lumen of the recording element 218. As shown in Figure 20b, housing 217 includes a marking mechanism 224 located on the upper portion 226 of the

housing, at or within window or aperture 230. An indexing indicator 228 is located on the lower portion 227 of the housing 217, at window or opening 229.

Turning to Figure 20c, recording element 218 is inserted in housing 217 of measuring and mapping device 210, so that the distal end 225 of recording element 218 appears through opening 232. Tensioning means (not shown) in the device 210, enables recording element 218 to move longitudinally within housing 218. With the guide pin 20 replaced, the measuring device 210 is inserted on the guide pin on reference axis 20A so that key-shaped surface 221 engages the corresponding keyed surface of the screw and is maintained in static position thereby. These key-shaped surfaces establish the rotational position of the articular surface points to be mapped relative to the screw. During the measuring and mapping procedure, the surgeon rotates housing 217 and outer arm or outrigger 231 located at the distal end 235 of housing. By depressing marking mechanism 224, a series of depressions or marked points 240 is established in the relatively soft surface of the upper portion 219 of the recording element 218, which deforms at these marked points so that they can be utilized as patient data. Indexing indicator 228 and calibrated lower portion 220 of recording element 217 allow for controlled rotational movement between housing 217 and recording element 218. In this way, the rotational position of the mapped articular surface points 235 relative to the screw 10 as appreciated by outer arm of outrigger 231, is translated to the implant geometry as a feature so that the accurate rotational location of the implant 40 relative to the screw 10 is maintained.

For example, as shown in Figures 8b and 9b, to accurately reproduce the two radii 60 and 61 that locally define the articular surface 55, four points, 81a and 81b, and 82a and 82b, and the point of origin 80 are recorded. As any three points in a single plane define a curve, by recording points 81a and 81b and the point of origin 80, radius 60 defining the medial-lateral aspect 68 of the chondyle can be determined. By recording points 82a and 82b and the point of origin 80, the radius 61 defining the anterior-posterior aspect 69 of the chondyle can be determined. In the example provided, in order to maintain the relationship between these two defined radii, 60 and 61, the measuring tool 70 is constructed so that it can be accurately indexed from a fixed starting point along 90 degree intervals to capture or map said four points 81a, 81b, 82a and 82b, over the course of its revolution.

Locating surfaces or features created on the radius cover 30, or along some length of the fixation screw 10, hex-shaped drive surface of the screw 14 or on the cylindrical proximal

extension (or recess) of the screw 14, correlate to some surface or feature on the measuring tool 70 and allow the measurement of the rotational position of the four measured points 81a, 81b, 82 and 82b, about the reference axis 20A with respect to said locating surfaces. This data becomes important in configuring the implant 40 with respect to the fixation screw 10 so that the proper orientation of said measured points to fabricated geometry is maintained. Of course, such measuring tool can be configured to measure any number of points at any interval desired.

While the measurements are illustrated in Figures 9a and 9b as being taken from the bottom of the radiused surface 31 of the hex-shaped cover 30 of the screw, the measurements may alternatively be taken from the top of the screw 10' itself, as shown in Figure 9c. As shown, in this embodiment, a key 315 or other alignment feature may be provided, to indicate the starting point for taking measurements. In this configuration, the measuring tool used, as well as the implant manufactured, both have a mating feature matching the key 315, for properly locating the starting point of the measurements taken and thereby subsequently properly aligning the implant with respect to the defect.

Other embodiments of measuring and recording tools are possible. One such embodiment of a measuring and recording tool 210' is shown in Figures 20d – 20i. As shown, measuring tool 210' comprises a handle 316, outer shaft 333, inner shaft 330, scroll 317, a tactile feedback portion 318, ring 320 having a button 321 in communication with a sharp marking point 326 thereunder, a rotating portion 322 having a rotational lock 323 which prevents rotation of the rotating portion 322 when engaged, and an outrigger portion 324. The handle 316 remains fixed during rotation and does not move while the tool 210' is used for measuring. Instead, the rotating portion 322 is rotated to a start position and the rotational lock is engaged, securing the rotating portion 322 to the tactile feedback portion 318 and thereby preventing its rotation. The scroll 317 is configured with a notch 325 or similar mating feature to align with a corresponding mating feature (not shown) of the handle 316, such that the scroll can only align at one rotational point, at 0 degrees, with respect to the handle 316 upon loading into the tool 210', e.g., by "snapping" into place. The sharp marking point 326 located inside the ring 320 under the sharp marking point 326, marks a point of depression into the scroll 317 while first button 321 is being depressed. Instead of marking by making depressions on a scroll or spool, marking could alternatively be made upon nearly any surface, e.g., using ink to record on a paper spool, or by digital means.

As shown in Figures 20f and 20g, outer shaft 333, which is fixedly coupled to rotating portion 322, outrigger 324 and ring 320, is freely rotatably disposed about inner shaft 330 and slidably disposed about inner shaft 330 within a range bounded by points 334 and 337. In Figure 20f, the outrigger 324 is retracted, and outer shaft 333 is located at a position of origin along a z-axis parallel to the inner 330 and outer 333 shafts, such that the proximal end of the ring 320 is located at position 335. In Figure 20g, the outrigger 324 is extended, and outer shaft 333 is located at a position .250 in. (.64 cm.) from the origin of the z-axis parallel to the inner 330 and outer 333 shafts, such that the proximal end of the ring 320 is located at position 335'. The motion of the sliding of the outer shaft 333 about inner shaft 330 during marking is translated via the outer shaft 333, rotating portion 322 and ring 320 (including marking button 321 and marking point 326) to a location along the scroll 317. Thus, as the user rotates outrigger 324 by rotation of rotating portion 322, the outrigger moves along the articular surface proximally or distally with respect to the inner shaft, and the displacement of the outrigger 324 along a z-axis parallel to the inner 330 and outer 333 shafts may be marked on the scroll 317 by depression of the button 323 at various points along the rotation of the outrigger 324. The tactile feedback portion 318 has a series of depressions 319 or other tactile feedback means, e.g. spring ball plungers which engage in indentations (not shown) in the inner shaft 330, spaced at 90 degrees from one another, so that when the rotational lock 323 is engaged as rotating portion 322 is being rotated, the user feels a "click" or other tactile feedback to indicate to the user the rotational location of the rotating portion 322 at 90 degree intervals with respect to the handle 316, i.e., at 90 degrees, 180 degrees, 270 degrees, and 0 (or 360) degrees, for purposes of marking at those points. It is further noted that the starting point for marking may or may not be selected independent of the 90-degree rotational points, and that the rotating portion 322 may or may not be configured so that it is not tied to the 90-degree indexing until the scroll lock 323 is engaged.

As shown in Figures 20e, 20h and 20i, a keyed mating feature 331 may be disposed at the distal end of the inner shaft 330 with respect to the outrigger portion, for mating with a key feature 315 on the screw 10' (as shown in Figures 9c and 20i), so as to locate properly the starting point of the measurements taken with respect to the screw, and the scroll 317. Figure 20h illustrates a more detailed view of the distal end of the marking tool 210', with outer shaft 333, inner shaft 330 with keyed mating feature 331, and outrigger 324 with rounded end 338, which travels along the path of circle 339. Figure 20i illustrates the measuring tool 210', with

the keyed mating feature 331 inserted into the recessed portion 303 of the screw 10' at its fixation element 302.

Referring now to Figure 14a, data recorded during the mapping procedure described above can then be entered into a known parametric engineering design software or similar algorithm, as four values, 85a, 85b, 85c, and 85d, corresponding to the four measured points, 81a, 81b, 82a and 82b, with the origin 80 defining a reference plane. These four values 85a, 85b, 85c and 85d, are represented by line elements that are geometrically constrained to lie upon a circle 90, which represents the diameter of the measuring tool 70. These line elements are also constrained to lie within planes that are perpendicular to one another. Of course, more than four points may be taken and used to map the articular surface, e.g., 8 points; however, a minimum of four points should be taken, so that two intersecting datum curves may be defined for purposes of mapping.

Datum curves 86 and 87, representing the medial-lateral ("ML") and anterior-posterior ("AP") curves, are constructed by connecting the end points of the line elements 81a and 81b, and 82a and 82b and the point of origin 80, which is common to both curves. These two datum curves 86 and 87 can be used to construct the articular or bottom surface 41 of the prosthetic implant 40. By sweeping datum curve 87 along a path defined by datum curve 86, a three dimensional surface is now defined.

By constructing this series of geometric relationships in a known parametric engineering model, patient-specific geometry can be input as values and the model algorithm can be run to reproduce the anatomic contours mapped in the patients within only a few moments. As a process, this generic model is the starting point for all patient treatments. Sterile pins, screws, and measuring devices that are all non-patient-specific may be stocked in the hospital and ready to use whenever an appropriate defect is diagnosed. Patient-specific data may be transmitted from the surgeon to the fabricating facility via an interface to the Internet or other network. Data input into the interface may be read directly into the generic parametric model to produce a viewable and even mappable patient-specific parametric model within moments. Confirmation by the surgeon could initiate a work order for the production of the patient specific device. Existing technology allows the parametric model to generate toolpaths and programming, e.g., to

a CAD/CAM system comprising appropriate hardware and/or software coupled to appropriate data-driven tools, to fabricate the implant.

Defining two additional datum curves 88 and 89, at offset distances from datum curves 86 and 87, is performed to define the top or non-bearing surface 42 of the implant 40. This top surface 42 should be closely matched to the bearing surface geometry to be implanted without having to remove an excessive quantity of bone from the chondral surface.

Referring to Figures 14c and 19c, implant geometry may be defined whereby the top or bone contacting surface 42 of the implant 40 exhibits an axial symmetry. The central axis AA passes through the point of origin 80 of the implant 40 and when the implant is positioned at the target site, aligns with the original reference axis 20A as defined by the guide pin 20 and fixation screw 10. The central axis AA can then be used to define the preparation tools so that the bone contacting surfaces 42 of the implant 40 and the preparation tools can be matched in both configuration and dimension to create a mating fit between the surface of the prepared target site and the bone contacting surfaces 42 of the implant. For example, if the preparation tools can be fabricated using some of the same dimensions obtained during the articular surface mapping procedure, the implant geometry and corresponding preparation tool geometry can be mated and optimized so that a minimum vertical thickness of the implant as well as a minimum depth of bone removal is required. This may be advantageous in ensuring good long term clinical results with the implant, as poor quality of fit between bone surfaces and bone-contacting surfaces of traditional orthopedic prosthetic devices has been noted to contribute to early clinical failures.

For example, as shown in Figures 14c and 19c the top or bone contacting surface 42 of the implant 40, a series of radial cuts 198 may create surfaces that increase resistance of the implant to rotational forces. These features may be located at the outer diameter 190 of the implant 40 to increase their effectiveness. Additional contact surfaces may also be created by one or more protrusions 195 located on the bottom 42 of the implant. Similarly, surface treatments known in the field of orthopedic devices, such as porous and/or osteoconductive coatings, may be utilized on surface 42.

As shown in Figure 19b, outer diameter 190 may include a slight outward taper or protrusion 197 along the diametrical surface to enhance load bearing or load transfer properties of the implant to surrounding bone. This feature may also increase the fixation strength of the

implant. A fillet 199 (as shown in Figure 19a) that runs around the implant at the intersection of the diametrical surface 190 and the bearing surface 41 is also useful in providing a smooth transition between the host articular cartilage and the implant surface.

However, if a greater depth of implant is needed as a result of the defect appearance the offset curves 88 and 89 (as shown in Figure 14a) can be extended to increase the overall thickness of the implant 40 or the offset curves may be eliminated entirely so that the contoured surface is backed by a revolved geometry that is symmetrical to reference axis 20A. Turning to Figure 19c, where the ML curve and AP curve (defined by the obtained measurements) are not axially symmetrical, the thickness of the implant 40 requires adjustment. At the same time, an unnecessarily thick implant requires a greater amount of bone to be removed at the target site. Therefore, the thickness of the implant may be determined by taking the largest obtained measurement and adding a minimal offset amount 208. (The implant is thinnest at the highest point on the ML curve.) This can be similarly accomplished by adjusting the angle α (Figure 19a) of the bone-contacting surface 42 of the implant 40 and a corresponding angle of the preparation tool. This also allows for a correction of the implant geometry, to compensate for any non-perpendicular placement of the guide pin with respect to the articular surface.

With reference now to Figures 25 and 26, an exemplary algorithm consistent with the invention establishes the minimum thickness of an implant necessary to include all patient data points, receiving as input all of the points measured (typically, four) and identifying the largest value. One such exemplary algorithm is as follows (and as shown in Figures 25 and 26):

```

maxval= D6
    if maxval < D11
        maxval = D11
    endif
    if maxval < D14
        maxval = D14
    endif
D684 = maxval + .045

```

In the foregoing exemplary algorithm, a first data point D6 is initially assigned as the maximum value (maxval). If...then type statements are used to compare other data points (D11 and D14) to maxval. If other data points are greater than maxval, the algorithm reassigns maxval to the new larger data point. LLMT represents the height of the lower limit plane along the z-axis, and ULMT represents the height of the upper limit plane along the z-axis. D684 is a dimension that controls the ULMT plane, which is established in the model as the upper surface of the implant. ULMT is positioned as maxval plus an additional arbitrary and/or fixed material offset (.045 in this case).

Figures 5c and 5d illustrate an alternative embodiment of the implant 40', having a ML curve between data points 340 and 341 and an AP curve between data points 342 and 343, with male-shaped mating component 304 and key-shaped portion 344 for engagement with a reciprocal key-shaped surface in the proximal extension of a fixation screw, protrusions 345 (creating contact surfaces on the top 346 of the implant 40'), radial cuts 347 located at the outer diameter 348 of the implant 40', and radius 349 (which may be formed, e.g. using an abrasive wheel) around the intersection of the outer diameter at point 341 and the surface comprising the patient geometry.

Referring to Figures 18a and 18b, bone cutting or scoring instrument 250 includes a handle (not shown), a cannulated shaft 111 that extends through the handle, and offset arm 140 housing adjustable blades 141. In the embodiment shown, individual cutting blades 141 are attached to offset arm 140 either fixedly or removably, e.g. via threaded portions 142, into threaded recesses 342 of the offset arm 140, although other attachment means may be used. With guide pin 20 advanced through shaft 113 positioned on the reference axis 20A, a fixed distance from the rotational or reference axis 20A to each of the cutting or scoring blades 141 is established. These lengths define the radii that are to be effected in the articular surface, as the scoring instrument 250 is rotated around the guide pin 20, corresponding to the protrusions 195 on the bone contacting surface 42 of the implant 40 creating a matching fit between the bone surfaces of the prepared target site and the bone contacting surfaces of the implant.

In an alternative embodiment, as shown in Figure 18c, cutting blades are arranged on carrier 145, configured so that it can be mounted within the slotted surface 114 of offset arm 112, depicted in Figure 17a. In another embodiment, as shown in Figure 18d, cutting blades 141 can

be fixedly positioned on offset arm 140. Using the same dimensions obtained during articular surface mapping procedure, the cutting and scoring device 250 can be fabricated to prepare the articular surface to correspond to the implant geometry to optimize fit. In another alternative embodiment, as shown in Figure 18e, a bone cutting instrument 352 corresponds to the alternative embodiment of the implant 40' illustrated in Figures 5c and 5d. Instrument 352 has a handle (not shown), a cannulated shaft 353 that extends through the handle and through the cannulation 355, offset arm 354 with blades 350 and 351 corresponding to the protrusions 345 on the bone contacting surface 42 of the implant 40 creating a matching fit between the bone surfaces of the prepared target site and the bone contacting surfaces 346 of the implant 40'.

As shown in Figure 14b, an angular dimension 95, relating some locating surface or feature on the hex-shaped cover 30 or on the fixation screw 10, to the four points 81a, 81b, 82a and 82b, may also be captured at the time of the initial procedure to assist in orientation of the implant 40 to the fixation screw 10. Guide aperture 46 in implant 40 is located off the reference axis 20A and may serve as the locating feature and/or as a suture passage way in the implantation procedure. Alternatively, a surface or feature created on the implant 40, may serve to reference or align to such locating surface on the hex-shaped cover 30 or the fixation screw 10.

Additional data can be taken at the time of the initial procedure, e.g., for fabricating a non-circular implant. Additional data curves can also be defined by measuring the offsets from the reference axis 20A and determining diameters at these offsets. The final implant geometry, although measured using circular techniques, need not be circular.

Referring to Figures 10a and 10b, following fabrication of the implant 40, a second procedure is performed. If a cover 30 (or plug) is in place, it is removed, exposing proximal extension 14 (or recess) or some other precision taper or engagement surface located at the proximal end 17 of the fixation screw 10 to which the implant 40 is to be affixed. A pin having a distally mounted element or barb 5 is placed through through hole 16 running through the central lumen of the fixation screw 10 so that the distally mounted element 5 is secured into the screw. The distally mounted element 5 carries one or more suture strands 85 that now trail from the fixation screw 10. Alternatively, a pin, braided cable, or flexible wire may also be used.

However, sutures may make passing the implant 40 through the incision 200 and subsequent handling easier.

Turning to Figures 11a and 11b, the sutures 85 are then threaded through guide aperture 46 of the implant 40 and a knot or bead 49 may be created proximal to the implant, so that tensing one of the free running sutures 85 helps to advance the implant 40 toward the proximal extension 14 (or recess) of the fixation screw 10. Alternatively, the suture strands 85 can be passed through the central lumen or shaft of a driving rod or other instrument to aid in seating the implant 40, and positioned in the fixation screw 10 thereafter.

If necessary, the arthroscopic wound 200 is expanded slightly in either a vertical or horizontal direction, so that the implant 40 may be passed through. A polymeric sleeve (not shown) positioned over the implant may prove helpful in passing the implant through the incision. As shown in Figure 11b, based on the size of the implant 40, anatomy of the knee 50, and retraction of the knee, it may be necessary to position the implant in the interchondular notch 77 as a staging area prior to final placement. By continuing to manipulate and tension the suture strands 85, the implant 40 can be brought coaxial to the proximal extension 14 of the fixation screw 10.

As shown in Figures 15c and 15d, alternatively, driver 130 includes handle 110, a cannulated shaft 111 that extends through the handle and a cannulated seat portion 131 attached to the end of the shaft. Tether element 135, which may comprise sutures or wire, is passed through driver 130 and is threaded through implant 40 through guide aperture 46, connecting the implant to the driver toward seat portion 131. The implant 40 and the driver 130 are then inserted arthroscopically through incision 200 to the target site. By tensioning tether element 135 at the end 136 of handle 110, the implant 40 is drawn back into seat portion 131 of driver 130. By maintaining tension on tether element 135, the implant 40 can then be controllably delivered to the prepared target site. At least the inner surface of seat portion 131 comprises a material that can be impacted to seat the implant 40 without damaging the implant surface.

Referring to Figure 12, once coaxial, the implant 40 can be aligned via engagement of the proximal extension 14 on fixation screw 10 and precisions taper 44 on the bottom surface 42 of the implant and any locating feature, and driven into place with a plastic driving rod 91 and

mallet 95. A protrusion 92 of high strength material mounted at the distal tip 93 of the driving rod 91 may be necessary to ensure that the rod stays centered on the implant 40 during driving.

Finally, as shown in Figure 13, through guide aperture 46 on the upper surface 41 of the implant 40, bone cement 300 may be injected to enhance the contact surface between the implant 40 and the subchondral bone 100. Vents, such as milled slots 13 in the fixation screw 10, and in the walls of the implant central protrusion may be desirable to facilitate the flow of such materials.

Alternatively, guide aperture 46 in the implant 40 may be altogether eliminated by using an alternative implant delivery system, as shown in Figures 19d through 19i, corresponding to an implant similar to that shown in Figures 5c and 5d. The alternative system comprises the implant 40'' and a washer 361 for holding a suture 363, the washer 361 being adapted to fit into a taper lock ring 360. The ring 360 has a taper lock portion 362 having a series of notches 365 along its perimeter, creating flaps 372 that permit the taper lock portion 362 to flex somewhat. The taper lock portion 362 has a diameter gradually tapering from the middle to the proximal end 364 of the ring. The taper lock ring 360 may also have an alignment notch 386 or similar feature for properly aligning the taper lock ring 360 with respect to key-shaped portion 344 of the implant 40'', which is to engage with a reciprocal key-shaped surface in the proximal extension of a fixation screw, so as to seat properly the implant rotationally with respect to the defect site when it is later seated thereon. A washer 361 is disposed between the ring 360 and the implant 40'' and has two apertures 366 disposed in a recessed area 367 in the center of the washer. The suture 363 is threaded through the two apertures 366 to form a suture loop 368, which remains in the recessed area when the ends of the suture 363 are pulled, so as to keep the suture loop 368 below the top surface 369 of the washer 361. The implant 40'' has a diameter at its center portion 370 that is approximately equal to the inner diameter of the ring 360 at its taper lock portion 362. Thus, when tension is applied to the ends of the suture 363, the taper lock portion 362 of the ring 360 may flex outward to receive slidably therein the implant 40'' and washer 361, which subsequently lock into the taper lock portion 362 of the ring, once the center portion 370 of the sides of the implant 40'' is seated within the proximal end 364 of the ring by friction fit, as shown in Figure 19e. It is noted that the center portion 370 of the sides of the implant 40'' to be of a width permitting the implant and washer to travel slidably within the ring 360 to some degree.

As shown in Figure 19f, a hex nut 373 may be integrally formed in the center of the washer 361 on its bottom side 374, for mating with an appropriately configured tool for seating the implant 40''. As Figure 19f illustrates, the implant 40'', along with washer 361, ring 360, and sutures 363, is pushed through the incision 200 at the defect site. Next, as shown in Figures 19g – 19i, illustrative of successive steps in the process of seating the implant, a seating tool 380 may be used to seat the implant. Seating tool 380 comprises a shaft 385, a handle 381 (which may have a through hole 382, if the same handle and/or shaft is used with interchangeable tips for performing various functions, although a through hole 382 is not integral to seating the implant), and tip 383 suitably configured to drive hex nut 373 (or other mating feature) and having an aperture 384 through which the ends of the suture 363 may be threaded. Once the tip 383 of the tool 380 is introduced into the incision 200, the sutures 363 may be used as a guide for seating the tip 383 of the tool 380 onto the hex nut 373, which may be accomplished by alternately pulling on each end of the suture 363 to toggle the tip 383 of the tool 380 back and forth. Once the tip 383 of the tool 380 is seated onto the hex nut 373, the tool 380 may be rotated in either direction to seat the implant assembly properly (comprising implant 40'', taper lock ring 360, and washer 361) at the defect site. This may be effected by rotating tool 380 until alignment notch 386 and corresponding key-shaped portion 344 of the implant 40'' are aligned with the corresponding reciprocal key-shaped surface in the proximal extension of the fixation screw, whereby the implant should slide into place, thereby properly seating the implant rotationally with respect to the defect site. As shown in Figure 12 with respect to the prior described embodiment, once properly seated, the implant 40'' can be driven into place with a plastic driving rod 91 and mallet 95, and as shown in Figure 13 with respect to the prior described embodiment, bone cement 300 may also be placed prior to the final seating of the implant 40'' to enhance the contact surface between the implant 40'' and the subchondral bone 100. It should be understood that the taper lock ring 360, washer 361, and sutures 363 described with respect to this embodiment allow the implant to be noncannulated but still easily handled. These elements are not required to be constructed as illustrated herein, and may be replaced by adhesive components, suction components, or other components serving the same function.

As Figures 21 and 22 illustrate, a unitary (one-piece) implant 400 may also be constructed, thereby obviating the need for a fixation screw, taper lock ring, washer, and suture. In this embodiment, implant 400 has key-shaped portion 401 for engagement with a reciprocal

key-shaped surface 411 in an aperture 412 at the defect site 410, a plurality of barbs 402 (or other mating features, e.g., one or more threads, ribs, fins, milled slots, tapered distal features, features to prevent rotational movement of the implant, or features to increase friction between the implant and the aperture at the defect site) for producing outward tension within the aperture 412 at the defect site 410 and for increasing the contact surface area of the implant 400 with respect to the aperture 412 at the defect site 410. In this embodiment, an aperture 412 having a key-shaped surface 411 or other feature for mating with the implant is created directly in the defect site 410, by boring, abrasion, or other techniques for forming an appropriately shaped aperture in the chondral bone 410 for receiving an implant 400 having a corresponding key-shaped or other mating feature 401. It should also be recognized that, in this or other embodiments, the fixation screw could be replaced with a tensioned member attachment, e.g., anchored to the distal femoral cortex. Alternatively, the fixation screw could be configured as a guide wire, only to define the axis AA corresponding to an axis about the point of origin in the implant to be used (as shown in Figures 14c and 19c), but not to provide mechanical anchoring to or for the implant.

Figure 23 illustrates other alternative embodiments for an implant consistent with the invention, showing a perspective view of the components of an exemplary composite implant, in one embodiment of the present invention. As shown, implant 500 comprises top 501 and bottom 502 portions. Top portion 501 has a bottom surface 503 which may be glued, welded, bonded, or otherwise attached to top surface 504 of bottom portion 502, while bottom surface 505 of bottom portion 502 comprises the patient geometry and is the load-bearing surface of the implant, as set forth hereinabove. Top 504 and bottom 505 surfaces of the bottom portion 502 may comprise, in whole or in part, bioengineered material, while top portion 501 may comprise a material such as titanium. In such a configuration, top portion 501 may be fabricated and/or manufactured (e.g. in large quantities) as a universal, generic, standard supply item for medical practitioners, which merely needs to be attached to a custom-machined bottom portion 502 comprising the patient-specific geometry. Surfaces 503 and 504 may be flat or may comprise other mating features, shapes or configurations.

Further composite implant embodiments are illustrated in Figure 24, wherein implant 600 comprises the patient-specific geometry 603 and a uniform thickness material bottom portion 602 comprising the bottom or bearing surface 606. The bottom surface 603 of top portion 601

mates with the top surface 604 of bottom portion 602, and surfaces 603 and 604 may be flat or may comprise other mating features, shapes or configurations. Lip 605 of bottom portion 602 has an inside diameter substantially the same as the outside diameter of top portion 601, so that top portion 601 fits slidably into bottom portion 602, whereby the two portions 601 and 602 may be glued, welded, bonded, or otherwise attached to one another. Bottom surface 606, being of uniform thickness, reflects the patient-specific geometry which surface 603 comprises and is the load-bearing surface of the implant.

Other materials from which an implant consistent with the invention may be constructed, in whole or in part, include ceramic, e.g. aluminum oxide or zirconium oxide; metal and metal alloys, e.g. Co-Cr-W-Ni, Co-Cr-M, CoCr alloys, CoCr Molybdenum alloys, Cr-Ni-Mn alloys, powder metal alloys, 316L stainless steel, Ti 6Al - 4V ELI; polymers, e.g., polyurethane, polyethylene (wear resistant and cross-linked), thermoplastic elastomers; biomaterials, e.g. polycaprolactone; and diffusion hardened materials, e.g. Ti-13-13, Zirconium and Niobium. Coatings used may include, e.g., porous coating systems on bone-contacting surfaces, hydrophilic coatings on load-bearing surfaces, hydroxyapatite coatings on bone-contacting surfaces, and tri-calcium phosphate on bone-contacting surfaces. Additionally, components of the invention may be molded or cast, hand-fabricated, or machined.

Alternatively, measurement methods may be utilized whereby radius measurements are taken with respect to an axis AA corresponding to an axis about the point of origin in the implant to be used (as shown in Figures 14c and 19c). The technique is used in reverse, whereby aiming devices are used to place axis AA with respect to prefabricated generic-geometry implants.

It is noted that, although the invention is herein described as utilizing a single reference axis, multiple reference axes may be used for measuring, mapping, or cutting a single defect or an articular surface having multiple defects, as well as for fabricating a single implant, or multiple implants for a single articular surface, consistent with the invention. In other embodiments, methods for mapping the defect and/or articular surface other than those described hereinabove are possible, e.g., MRI or CT scanning, fluoroscopy, ultrasound, bone density, other stereotactic systems, nuclear medicine, or other sound or light wave-based imaging methods.

It is further noted that, although the invention is described herein as utilizing the specific geometry of a patient's articular surface to fabricate an implant for that patient, it is contemplated

that data from a plurality of patients may be analyzed statistically and utilized in fabricating and/or manufacturing (e.g. in large quantities) one or more universal, generic, or standard supply item type implants for medical practitioners to use in a procedure consistent with the invention. For such implants, as well as for patient-specific implants as described herein, pre- or post-implantation trimming may be required to correct for minor variations that may occur as between the implant and the subchondral bone (or other articular surface).

It should be understood that, although the various tools described hereinabove, e.g., for measuring, cutting, and seating, are described as separate devices, a single handle, shaft and/or instrument may be configured to serve as a universal mounting tool for a series of devices for performing various functions consistent with the invention.

Generic Bone Resurface Implant, Cutting Tool, and Procedure

Figures 27a-48 depict another exemplary embodiment of the present invention. In this embodiment a generic bone implant (or set of standardized implants) is created (or selected) based on developing an axis normal to the surface and collecting only one data point. In the above-described embodiments, a non-normal axis was utilized, and four data points were required to develop ML and AP curves. Further, a generic cutting tool is used to cut the bone at this site to a point where a generic implant can be used. Several improved tools relating to the procedure for using such an implant (as well as for using implants as described hereinabove) are further described in this section and illustrated in the corresponding figures.

Figure 27a depicts an exemplary drill guide device 700 according to this exemplary embodiment. The guide 700 includes a contact surface 702 of known diameter d on the distal end 708 of the guide, where diameter d is generally the width of the widest portion of the site of the lesion. The distal end 708 of the guide is generally a hollowed-out toroidal structure attached to a handle 706. A central lumen 704 runs the length of the guide from the attachment point of the distal end 708 to the handle 706, and through the handle 706. The guide device may be constructed in a number of other ways, including, e.g., a distal end 708 comprising a transparent material, e.g., polycarbonate or another clear plastic. For example, as shown in Figure 27b, a guide device 700' may comprise a distal end 708' (which could comprise either an opaque or a transparent material) having a plurality of cutaway areas 743 to improve visibility and the accuracy of drill location with respect to the site of a lesion. The guide device may also comprise a tripod-like construction, or other construction comprising fins, or projections. It

should be noted that, instead of a central lumen being used to locate the working axis, a cylindrical bore located at some distal location of the guide may serve to create a working axis that is not necessarily coaxial to the handle or connecting shaft of the instrument.

Referring now to Figures 28a and 28b, the present embodiment operates on the assumption that to a first approximation an anatomical model of some articular surfaces (e.g., knee, hip, etc.) can be assumed to be locally spherical. In other words, as shown in Figures 28a and 28b, the AP plane and ML plane, respectively, are depicted, wherein each corresponds to a model of the articular surface of a femoral region. These figures break up these cross-sections into a plurality of radii of arcs defining the articular surface, i.e., R_1 - R_4 in the AP plane, and R_5 - R_7 in the ML plane. In this embodiment, the inventors herein have found that surfaces in some regions can be assumed to be substantially locally spherical. Thus, for example, the present embodiment assumes that R_3 approximately equals R_6 (i.e., R_3 is within 50% of R_6). Under these assumptions, a normal axis can easily be developed. Once developed, one data point then needs to be defined to obtain the relevant geometry of an implant, as will be described below. If R_3 is not within 50% of R_6 , an alternative method for developing an axis normal to the surface of the lesion site, as described hereinbelow with reference to Figures 49-53, may be used.

Figures 29-34 depict the use of the drill guide, the generic implant, and procedures therefor, according to this exemplary embodiment. In Figure 29, the drill guide 700 is brought up to a lesion site 712 of the articular surface 710. The guide 700 is positioned so that the distal end 702 covers the lesion site 712, such that the contact surface of the distal end 702 makes contact at a plurality of points around the lesion site 712 on the articular surface 710. As shown in Figure 30, with slight pressure the guide 700 becomes stable and fixed on the articular surface 710. Once seated in position, a guide pin 714 is driven through the central lumen of the guide to create a working axis that is generally normal to the articular surface 710 at the point of contact of the guide pin. As Figure 31 illustrates, a standard bore drill (not shown) can be placed over the guide pin 714 to create a pilot hole 716 for the screw (not shown).

With reference now to Figure 32, as with the previous embodiments described above, a screw 720 is driven into the pilot hole 716. A cap 722 having a male component 719 adapted to mate with the female taper 718 of the screw 720 is placed on the screw 720. The screw is driven to the appropriate depth, such that the top surface of the cap 722 is substantially aligned with the articular surface 710, within the lesion site 712, thereby ensuring congruency of the implant to

the joint. Turning now to Figure 33, the cap 722 is removed, and a rod 730 having a mating taper 731 on its distal tip is inserted into the screw 720. The guide 700 is positioned over the rod 730 so that the distal end 702 covers the lesion once again. As illustrated in Figure 34, since the length of the rod 730 and the length of the guide 700 are known, a measurement of the exposed end length of the rod (l) may be taken. This will provide the information needed with respect to the implant geometry, by indicating the distance between the seating depth in the screw and the tangent point of the implant surface. As shown in Figure 35, since the axis, z , is defined (by the drill guide) as normal to the surface of the implant at a plurality of points, all dimensions defining the AP and ML curves may be assumed to be equal, such that only one dimension, l , is left to define the implant geometry. Variations from knee to knee and within a knee may be reflected in changes in l . For example, the implant 736 of Figure 36 may be compared to the implant 737 of Figure 37. For implant 736 of Figure 36, the value of l_1 represents a relatively "flat" region on the articular cartilage, where the radius of the arc R_{AC1} is a relatively large number. However, for implant 737 of Figure 37, the value of l_2 represents a more curved region on the articular cartilage, where the radius of the arc R_{AC2} is a smaller number than R_{AC1} . As indicated by clinical data, there is a range of values for l that suggests 5 to 6 values of l that will fit a majority of people. Thus, generic, off-the-shelf sized implants may be made. A single procedure technique involving establishing the normal axis, measuring l , and selecting the appropriate size implant is therefore feasible.

As illustrated in Figure 38, an exemplary cutting or reaming tool 740 (e.g., as described hereinabove with respect to Figures 15b and 16) is used to prepare the lesion site 712 to receive the implant (not shown). The cutting or reaming tool 740 may be configured so that, when coupled to the axis defined by the guide pin, it can be used for cutting operations. The tool 740 may have a cannulated shaft and a distal offset arm having a cutting or blade surface (not shown) having a radius corresponding to the radius of the implant to be used, such that the articular cartilage may be circumscribed by rotation of the tool 740 for cleanly cutting the surrounding articular cartilage in preparation for receiving the implant. The tool 740 may be configured so that, when coupled to the axis defined by the guide pin, it can be used for cutting operations. The proximal face of the screw 720 may serve as a depth stop for the proximal portion of the tool 740, thereby defining a cutting/reaming depth corresponding to the thickness of the implant, l .

Those skilled in the art will recognize that the cutting tool may be motorized in certain embodiments, and/or alternatively, as illustrated in Figure 39, an exemplary cutting tool 744 may comprise a cannulated shaft 749, a circular blade portion 745 having a leading edge 746 comprising a blade surface turned on the distal-most portion. Such a tool 744 may further comprise a handle portion 747 and may be adapted to be turned by hand by the operator of the tool by means of rotating the handle 747, or alternatively, may be motorized in certain embodiments.

Figure 40 illustrates an exemplary cleaning tool 770 for cleaning the female taper (not shown) of the screw 720 prior to delivery of the implant. The distal end 771 of an exemplary cleaning tool 770 comprises a semi-rigid material formed into a shape adapted to enter into the female taper of the screw 720 and be manipulated by the operator of the tool, to remove tissue or other debris therefrom, thereby ensuring a good mate of the female taper 720 of the screw and the male taper of the implant to be delivered (not shown).

Figures 41-43 illustrate an exemplary suction tool 760 for holding the implant by means of a suction force and delivering it to the lesion site, as well as the steps of an exemplary procedure for using the suction tool 760 to deliver an implant. As illustrated in Figure 41, an exemplary suction tool 760 comprises an elastomeric suction tip 761 at its distal portion 767, a proximal surface 768, an inlet 762 for mating with a suction tube 763 connected either to a hospital wall suction supply 764 or other suction system, and a switch or valve 765 for controlling the suction force. As Figure 42 illustrates, when the suction force at the elastomeric suction tip 761 is activated by the switch or valve 765, the implant 742 is held in place, and thus, the suction tool 760 may be used to hold the implant prior to, and during, the delivery thereof. As shown in the cross-sectional view of Figure 43, the distal portion 767 of an exemplary suction tool 760 may comprise a rigid tip 766 (which may comprise, e.g., plastic material) disposed within the elastomeric suction tip 761. Force may be applied to the rigid tip 766 (e.g., by striking or pressing on the proximal surface 768 of the tool 760) in order to seat the implant 742 within the lesion site, once the male taper 769 of the implant 742 and its corresponding mating component(s) 778 are properly aligned with the female taper of the screw (not shown) and its corresponding mating component(s). Since the suction tip 761 is elastomeric (e.g., rubber), upon application of such force, the material will compress, allowing impact to be transferred to the implant 742 for purposes of seating it. It is noted that, in addition to its utility in delivering an

implant, a suction tool 760 as described herein (or a suction tool similar thereto) might also be used at some point during the process of removing an implant (e.g., in the event the implant is not fully seated).

Figure 44 illustrates an exemplary implant 742 driven into the lesion site 712 of the articular surface 710 once the site 712 has been sufficiently reamed or cut.

Figure 45 illustrates an exemplary implant removal or revision tool 750 comprising a shaft portion 751 and a distal portion 753, and Figure 46 is a cross-sectional view illustrating the exemplary tool 750 with a removed implant 742 being held in place therein. As shown, the distal portion 753 of the tool 750 may comprise an approximately cylindrical structure with a circular blade portion 752 having a leading edge 758 comprising a blade surface turned on the distal-most portion and a lip portion 755 disposed proximally with respect to the leading edge 758. A plurality of slits 754 parallel to the longitudinal central axis of the distal portion 753 are disposed along the length of the cylindrical structure, so as to permit sufficient outward expansion of the distal portion 753 to accommodate the top edge of the implant 742 therein. Thus, when the distal portion 753 of the tool 750 is forced onto an implant 742 to be removed, and driven down over the implant 742, the distal portion 753 will snap/lock into place once the lip portion 755 of the distal portion 753 of the tool 750 passes the top edge of the implant 742 being removed, thereby holding the implant 742 in place within the distal portion 753 of the tool 750, as shown in Figure 46. At this point, a device such as a slap-hammer or slide hammer (not shown) may be used to unseat the implant 742. An exemplary such device may comprise a shaft having a weight slidably disposed thereon, wherein one end of the shaft is connected to the proximal end (not shown) of the tool 750 and the other end of the shaft comprises a stop for preventing the weight from moving off the shaft, and wherein the weight is propelled away from its connection point with the proximal end of the tool 750, such that it stops abruptly at the stop and exerts a pulling force on the implant.

Alternative Embodiment of Screw

Figures 47 and 48 illustrate an exemplary alternatively-keyed embodiment of the screw 720' (c.f., key feature 315 of screw 10', as shown in Figure 9c) and the exemplary alternatively-keyed implant 742' to which it is adapted to mate. As shown, the male taper 769' of the implant 742' is coupled at its distal end to an offset mating feature 778' for mating with a corresponding offset mating feature 779 of the screw 720'. The mating feature 778' of the implant 742'

comprises a generally cylindrical structure (and may further comprise a rounded or chamfered distal end portion 777' and/or other geometric features, i.e., recesses and/or protrusions) and is both offset from the central longitudinal axis of, and diametrically smaller than, the male taper 769' of the implant 742'. As Figure 48 illustrates, a generally cylindrical recessed mating feature 779 (or similar mating recess(es) and/or protrusion(s), e.g., a rounded or chamfered distal end portion 780) corresponding to the offset distal mating feature 778' of the implant 742' is disposed within the innermost portion of the female taper 718' of the implant 742', and offset from the central longitudinal axis of the female taper 718'. The female mating feature 779 of the screw is provided to mate with the offset male distal mating feature 778' of the implant 742', so as to seat the taper 769' of the implant 742' at a fixed location within the screw 720', thereby preventing rotation of the implant 742' with respect to the screw 720'. Along with the mating features 778', 779, the taper structures provided may serve to prevent movement of the implant 742' with respect to the screw 720' in all directions. A screw 720' consistent with the present invention may comprise a titanium alloy, e.g., a 316L stainless steel alloy or a cobalt-chrome alloy.

Alternative Method for Developing Axis Normal to Lesion Site Surface

Figures 49-53 illustrate an alternative method for developing an axis normal to the surface of the lesion site using a biaxial measuring tool. This method has particular utility for lesion sites where the radii of arcs defining the articular surface, R_{ML} and R_{AP} , are different, i.e., the region is not locally spherical. (This would be the case, e.g., if R_3 is not within 50% of R_6 , as illustrated in Figures 29a and 29b and described hereinabove.) To develop an axis normal to the surface, a biaxial measuring tool 800 is provided. The tool 800 comprises an outer shaft 805 coupled fixedly to an outer component 801 having a set of arms 803, and an inner shaft 806 slidably disposed within the outer shaft 805, wherein the inner shaft is coupled fixedly to an inner component 802 having a set of arms 804. The arms 803, 804 of the outer 801 and inner 802 components may take several forms, and one exemplary form for the arms 803, 804 is illustrated in Figures 49-53, wherein the distal portion of each arm 803, 804 tapers outward and connects to one of four contact portions 808. The contact portions 808 may be, e.g., as shown, one of four arcuate sections of a generally toroidal member (which may be solid or hollow) having a generally circular cross-section. (The lengths of the arcuate sections do not necessarily need to be equal to one another, e.g., as illustrated in the exemplary contact portions 808 of

Figures 49-53, the arcuate lengths of the contact portions 808 corresponding to the inner component 802 are shorter than those contact portions 808 corresponding to the outer component 801.) The inner shaft 806 may be biased forward so as to tend to extend from the outer shaft 805, or may alternatively be advanced manually without spring bias. The inner component 802 is slid proximally or distally with respect to the outer component 801, until all of the contact portions 808 make contact with the articular surface (not shown). In this manner, the articular surface curvatures may be separated into AP elements and ML elements, such that four separate contact points may be extrapolated from the four contact portions 808, based on the relative positions of the inner 802 and outer 801 components, and an axis normal to the surface of the lesion site may be defined. The shaft of the tool 800 may be cannulated (not shown), so as to allow a guide pin or wire (or a boring tool) to pass therethrough and into the articular surface, as described hereinabove with respect to Figures 27a to 31. As shown in Figure 53, if the inner 802 and outer 801 components are aligned such that the four contact portions 808 meet to form a complete toroidal member or ring, the articular surface must be locally spherical, i.e., R_{ML} and R_{AP} (as shown in Figure 49) are equal, and it is therefore not necessary to use the biaxial tool 800.

It should be noted that, alternatively, contact surfaces may be constructed of some pliable, or malleable material(s) so that independently moving rigid mechanical members are not necessary. As long as the contact surfaces provide a normalizing force to some central shaft when the contact surfaces are applied to the articular surface, a normal axis could be defined.

In another embodiment, this biaxial guide could be replaced by a series of sized "trials" or gauges of predefined surfaces of varying dimensions, which are simply pressed onto the articular surface to visually determine an appropriate fit. These gauges may resemble an implant, as described herein, without any features (e.g., fixation element or screw) on the underside, and may contain a handling tab or other element for holding the gauge. The contact surfaces of these gauges may have a circular cross section, an ovular cross section, or another cross-section comprising a plurality of points to surround a defect in an articular surface, and the plurality of points may or may not lie in the same plane. Although they may be less precise or less accurate than other measuring methods described herein, it is contemplated that implant selection could be made directly from these gauges.

Digital Measuring System

Figures 54-61 illustrate an exemplary digital measuring system consistent with the present invention. As shown, the system 810 comprises a base unit 811 coupled to the handpiece 812 via a cable 813. As described further hereinbelow, the base unit 811 may comprise a tear strip 814 in or on the chassis for detaching a printed paper tape comprising measurement data. Such a system may reduce or eliminate potential for surgical or other human error with respect to the implementation of the present invention.

Figure 55 is an exploded view of an exemplary handpiece 812 in a digital system consistent with the present invention. The linear measuring elements of the handpiece 812 are nested concentrically and coaxially to the rotary measuring elements, so that when the probe assembly 818 is translated and rotated with respect to the main body 822 of the handpiece, the θ and z dimensions are simultaneously recorded. The handpiece 812 comprises a main body 822 containing a linear reading head 813 coupled to a linear reader 814, a linear index strip 815, a rotary reading head 821 coupled to a rotary reader 816, and a rotary index strip 817. The probe assembly 818 comprises a contact tip 819 coupled to an inner shaft 820 running along the length of the handpiece 812 disposed within the main body 822. The shaft 820 comprises a mating feature 834 at its distal end that is keyed to fit in the mating feature of an implanted screw, such that the shaft 820 provides a rotational axis. The shaft 820 is rigidly connected to the main body 822 of the handpiece 812 via a nut 823 at its rear. The handpiece 812 is coupled to, and transfers motion both rotationally and axially from, the contact tip 819 via the shaft 820. In this manner, the linear 815 and rotary 817 strips, which may comprise, e.g., mylar polyester film having thereon a very fine printed pattern, pass through the linear 813 and rotary 821 reading heads, respectively, such that the heads 813, 821 read the pattern on the strips 815, 817 and output data representing the rotational and axial travel of the contact tip 819.

Exemplary strips and heads may include those manufactured by U.S. DigitalTM Corporation of Vancouver, Washington, USA. Figure 55a is a cutaway view illustrating an exemplary printed linear index strip 815 passing through an exemplary linear head 813 for reading, and Figure 55b is a cutaway view illustrating two alternative exemplary printed rotary index strips 817, 817' of varying sizes passing through an exemplary rotary head 821 for reading. Figure 55c illustrates an exemplary linear index strip 815 comprising concentric "bullseye" circles 830, reference lines 831, a text area 832, and a pattern area 833. Figure 55d illustrates an exemplary rotary index strip 817 comprising an opaque area 823, index areas 824, a

pattern area 825, a text area 826, crosshairs 827, concentric "bullseye" circles 828 and a central aperture 829.

Turning now to Figures 56a and 56b, a rotational groove 840 and a linear groove 841 are provided on the handpiece 812, such that the probe assembly 818 may slide onto the shaft 820 of the handpiece 812 and snap into the linear 841 and rotational 840 grooves.

Figures 57 and 58 illustrate top and side views, respectively, of the assembled exemplary handpiece 812.

Figures 59 and 60 illustrate top and side cross-sectional views, respectively, of the assembled exemplary handpiece 812.

Figure 61 illustrates a cutaway view of an exemplary base unit 811 in an exemplary digital measuring system consistent with the present invention. The base unit 811 comprises a power supply 850 (the system may be battery or AC-line powered), a paper roll 851, a thermal printer 852, a feed loop dowel 853 for threading the paper roll 851 into the thermal printer 852, a set of controls or buttons 854, and one or more displays 855 (e.g., LED/LCD). The base unit 811 further comprises appropriate hardware and/or software to compare measured values to known values, as well as to compare sweeps to one another to ensure procedural accuracy. Further, the displays 855 and/or paper printouts from the thermal printer 852 may be adapted to display to the user, based on measured data, the ideal size of the generic implant to use. If a custom implant is required, a printout of the data set may be generated using the printer 852. The base unit 811 may further comprise other means of recording data (not shown), e.g., floppy disk, hard disk, memory/flash card, etc., and may further comprise appropriate hardware to provide output signals (e.g., via RS-232, USB, etc.) to external hardware. Instead of the strips, heads, and other recording elements described in the exemplary digital system hereinabove, other digital measurement methods may be used, including reflective light or sound methods, and percutaneous methods (e.g., using a hypodermic needle in conjunction with an MRI, CT, ultrasound, or other scanning method, wherein the needle or other handheld device comprises sensing elements for mapping the articular surface).

It should be noted that in the digital measuring system and method described hereinabove (as well as any of the mapping/measuring techniques herein), a second (or third, etc.) set of data points may be taken, and the subsequent set(s) of data points compared with the original data points taken, to reduce the margin of error from taking only a single set of data points. Thus, a

software algorithm in a system or method consistent with the invention may comprise appropriate routines to effect such comparisons, for error reduction purposes.

Further Alternative Implant Structures

Turning to Figure 62A, a top perspective view of an alternative exemplary implant 6200 that includes a protrusion 6204 that extends at least partially around the periphery of the device. In the exemplary embodiment, the protrusion 6204 is provided to cover at least a portion of an un-excised portion of articular surface, however, this is not a structural requirement of the device of the present embodiment. With a substantially round implant 6200 as illustrated in Figure 62A, the protrusion 6204 may surround the entire circumference of the implant 6200 and may extend radially outward from the center point P of the implant 6200. Alternatively, with other round and non-round implants as detailed further herein, the protrusion may be selectively placed around portions of the perimeter of the implant.

The implant 6200 may include a radial ring 6220 formed on the bone-facing distal surface of the implant 6200. The radial ring may be dimensioned to the excised portion such that the arcuate shaped outer side surface 6223 defines the size of the cut portion in the articular surface. The radial ring 6220 may have a width r_4 in a radial direction from the center point P of the implant 6200 and a height h_1 in the z-axis direction. The arcuate shaped outer side surface 6223 of the radial ring 6220 may be a radial distance r_1 from the center point P of the implant 6200. The radial ring 6220 may also include a plurality of radial slots 6224 spaced evenly along the circumference of the ring in order to assist with anchoring of the implant to the bone.

Turning the Figure 62B, a cross-sectional view of the implant 6200 taken along the line B-B of Figure 62A is illustrated. The radial ring 6220 is positioned relative to the center point P as it would be with other such implants earlier described, e.g., the circular implant illustrated in Figure 25 and 26. The protrusion 6204 is formed by an extension 6206 from the radial ring and an extension 6232 of the load bearing proximal surface. These extensions join at 6214 to define the protrusion 6204.

The top or proximal surface 6232 of the protrusion 6204 may simply be an extension of the proximal or load bearing surface 6205 of the implant 6200. As such, the protrusion 6204 extends beyond the outside arcuate edge 6223 of the radial ring 6220. Accordingly, the protrusion 6204 has a width r_3 at any one point along the perimeter of the implant 6200 equal to the difference between the radial distance r_2 from the center point P of the implant to the exterior

edge 6214 of the protrusion 6204 and the radial distance $r1$ from the center point P of the implant to the outside arcuate edge 6223 of the radial ring 6220. The width $r3$ of the protrusion may be a consistent width around the entire perimeter of the implant or may vary along the perimeter as conditions of the proximate articular cartilage vary.

The protrusion 6204 is also defined by a bone-facing or distal surface 6206 that may extend to cover a portion of the un-excised articular surface 6218. The distal surface 6206 of the protrusion 6204 may be shaped in any number of ways to match the mating edge of the articular surface 6218 proximate to the distal surface 6206 of the rim 6204. As illustrated in Figure 62B, the distal surface 6206 may have an arcuate shape for this purpose.

Turning to Figure 62C, a side perspective view of the implant 6200 is illustrated. As illustrated, the protrusion 6204 may be advantageously configured to follow the mapped contour of the mating articular surface, e.g., articular cartilage. In other words, the distal surface 6206 of the rim 6204 may vary along the perimeter of the implant in order to match the edge of the articular cartilage which it covers based on mapping configurations as previously detailed herein.

Turning to Figure 63A, a side perspective view of another alternative embodiment of an implant 6300 is illustrated. In this embodiment, the implant 6300 includes a protrusion 6304 with protuberances 6312a, 6312b, 6312c, and 6312d formed at selected locations along the periphery of the protrusion 6304, and may be used, for example, to secure the target articular surface proximate to the distal surface 6306 of the protrusion 6304. The protuberances 6312a, 6312b, 6312c, and 6312d may be any variety of shape or geometry and are preferably spaced equal distances around the outside perimeter of the protrusion 6304. The protuberances may also have barbs or teeth (not shown) to enhance grip to the articular surface. In the embodiment of Figure 63A, the interface between the implant 6300 and a fixation device, e.g., a screw, may need to be revised in order to allow more axial range of forgiveness for interlock of the protuberances to the articular cartilage.

Turning to Figure 63B, a cross-sectional view of the implant 6300 taken along the line B-B of Figure 63A is illustrated. As illustrated, the protuberances 6312a, 6312d couple to the distal portion 6306 of the rim 6304 in order to more securely couple the protrusion 6304 to the un-excised portion of the articular surface 6318 proximate to the implant 6300.

Turning to Figure 64A, another alternative embodiment of an implant 6400 is illustrated. In the embodiment of Figure 64A, the proximal or load bearing surface 6405 has a perimeter

edge 6406 that is configured to be separated a predetermined radial distance r_5 from a surrounding articular surface 6418 when the implant is properly seated in a patient. As such, a cavity 6428 or trough defined by a bottom cavity surface 6408, a side cavity surface 6406, and the cut side of articular surface 6418 is formed.

Turning to Figure 64B, a cross sectional view of the implant 6400 of Figure 64A taken along the line B-B is illustrated which further shows the details of such a cavity 6428. The articular cartilage 6418 may then settle or remodel into the cavity 6428. One side 6406 of the cavity 6428 may be arcuate shaped and may be depressed a predetermined distance relative to the load bearing surface 6405. The dimensions of the cavity may be large enough to permit sufficient space for the articular cartilage 6418 to remodel or settle into such cavity, but small enough so that articular cartilage 6418 may remodel into such space within a reasonable time frame after seating of the implant 6400.

Turning to Figure 65A, another alternative implant 6500 embodiment consistent with the invention is illustrated. This implant 6500 has a non-round or elongated shape. The concept behind this geometry of the implant is to provide extension of the implant in the AP plane without being constricted by the width of the condyle. In other words, the implant of this embodiment may be derived from a circular implant that has a radius that extends beyond the width of the condyle in the ML plane. The circular implant structure may then be truncated along the "sides" that form the edges of the condyle in the ML plane, thus forming the elongated implant depicted in Figure 65A. The implant 6500 has a least two side surfaces 6517, 6519 each having a concentric arcuate shape with a common center. As with implants described previously herein, the implant 6500 has an arc Arc_{AP} and an arc Arc_{ML} that represent the curvature of the proximal surface 6505 of the implant 6500.

The implant 6500 has a length from an anterior end of the implant to a posterior end of the implant along a segment of the arc Arc_{AP} . The implant also had a width from the medial end of the implant to the lateral end of the implant along a segment of the arc Arc_{ML} . Obviously, the arc segment in the ML plane is less than the arc segment in the AP plane, for the non-round or elongate shaped implant 6500.

The implant 6500 may also have one concentric arcuate shaped side surface 6517 located opposite another concentric arcuate shaped side surface 6519. Such side surfaces 6517, 6519 are concentric with a common center. Such side surfaces 6517, 6519 are also configured to mate

with a cut or reamed edge of bone and/or articular cartilage when seating the implant. The implant 6500 also has a length l_{6500} in a plane defined by the maximum distance between two points on the arcuate shaped side surfaces 6517, 6519.

The implant also may also have two other opposing side surfaces 6521, 6523. Such surfaces 6521, 6523 are generally flat to where the surface cutter "runs off" of the condyle. The distance in a plane between the two side surfaces 6521, 6523 define the width w_{6500} of the implant 6500. Having such an elongated or non-round implant allows the treatment of a greater variety of articular defects, and may also be effective in reducing fray between the perimeter of the cut articular cartilage and the implant 6500.

When articular surface mapping is done using one axis normal to the surface of the implant, two measuring probes may be utilized. One measuring probe may be utilized to map the points for the AP curve and another smaller diameter measuring probe may be utilized to map the points for the ML curve so as it is revolved it captures the data for points M and L. The implant 6500 may be defined by the ML curve swept along the AP curve as previously described herein. Alternatively, the implant may be a generic bone surface implant as previously described with reference to Figures 27a-48 assuming a locally spherical articular surface site.

Turning to Figure 65B, an implant site 6511 may be created by excising a portion of the articular surface 6508 to match the implant 6500 shape of Figure 65A. As such the implant site 6511 may have two arcuate shaped side surfaces 6531, 6533 located opposite each other to receive the two arcuate shaped side surfaces 6517, 6519 of the implant 6500. Two other side surfaces 6535, 6537 of the implant site are configured to mate with the side surfaces 6521, 6523 of the implant 6500.

The implant site 6511 may be generated a number of ways. In one instance, a reaming or cutting tool 6524 having a circular blade portion 6526 with a blade diameter d_{blade} greater than the width $W_{surface}$ of the articular surface 6608 to which the implant will be affixed may be utilized. Another exemplary reaming tool 744 is discussed more fully with reference to Figure 39. The circular blade 6526 of the reaming tool 6524 is depressed into the articular surface 6508 until it contacts the depth stops in the screw as previously described herein. A straight line distance d_{AP} is created since the blade diameter d_{blade} is greater than the width $W_{surface}$ of the articular surface 6608.

This straight line distance d_{AP} in an AP plane is dependent on a number of factors including the depth of the cutout bottom surface 6510 compared to the top or proximal surface 6505 of the implant, and the shape of the surrounding articular surface 6508 to which the implant will be applied. Once properly reamed, the implant site 6511 of Figure 65B should have a cross sectional view as illustrated in Figure 65C. As with prior cutouts, the cutout bottom surface 6510 will match the undersurface of the implant 6500.

Turning to Figure 65D, a perspective view of the elongated or non-round implant 6500 being placed into the implant site 6511 of the articular surface 6508 is illustrated. The implant 6500 may be placed and set into the implant site 6511 using any variety of tools and methods as previously discussed herein. The arcuate shaped side surfaces 6517, 6519 mate with edges 6531, 6533 of the implant site on the anterior and posterior side of the implant respectively. The other side surfaces 6521, 6523 abut the edges 6535, 6537 of the implant site on the medial and lateral side of the implant site. These side surfaces 6521, 6523 may be shaped to match that excised portion of the articular surface on such medial and lateral sides.

In one exemplary method of setting the non-round implant 6500, the diameter $\phi 1$ of one measuring probe may be used to define the diameter d_{blade} of a round blade 6526 from a reaming tool 6524. As such, the diameter $\phi 1$ of such a measuring probe may typically be equal to the diameter d_{blade} of the round blade 6526 from a reaming tool 6524. The diameter $\phi 2$ from another measuring probe may define the ML curve and hence the arcuate width of the implant along that curve.

Turning to Figure 66A, a top perspective view of another alternative exemplary elongated implant 6600 having two protrusions 6605, 6606 is illustrated. The protrusions 6605, 6606 may prevent fraying of the articular cartilage that abuts the anterior and posterior edge of the elongated implant 6600 when seated in an excised portion of an articular surface.

Protrusion 6605 is generally similar to protrusion 6606 so for clarity, description herein is made to protrusion 6606 only. Protrusion 6606 may extend radially from the arcuate shaped side surface 6623 to cover an un-excised portion 6634 of articular surface 6608 (see Figure 66B) proximate to the arcuate side surface 6623 of the implant 6600.

The protrusion 6606 has a width r_3 at any one point along the arc of the implant on the anterior side equal to the difference between the radial distance r_2 from the center point P of the implant to the exterior edge 6640 of the protrusion 6606, and the radial distance r_1 from the

center point P of the implant to the outside arcuate side surface 6623. The width r3 of the rim may be a consistent width around the perimeter of the arc or may vary as conditions of the mating articular cartilage vary. Although not illustrated, the protrusions 6605, 6606 of the elongated implant 6600 may also have protuberance to more securely affix the rim to the articular cartilage as described and illustrated earlier with reference to Figures 63A and 63B.

Turning to Figure 66B, a top perspective view of the elongated or non-round implant 6600 having protrusions 6605, 6606 being placed into an implant site 6611 of the articular surface 6608 is illustrated. The implant 6600 may be placed and set into the implant site 6611 using any variety of tools and methods as previously discussed herein. The protrusion 6606 may cover and anchor a portion of the articular cartilage 6634 proximate to the cut edge of the implant site 6611 at the anterior side, while the protrusion 6605 may similarly cover and anchor a portion of the articular cartilage proximate to the cut edge of the implant site 6611 at the posterior side of the implant.

Turning to Figure 67, a top perspective view of an implant 6700 being placed into a section 6707 of an articular surface 6708 is illustrated. Alternatively, in another method consistent with the present invention, the articular cartilage of the articular surface 6708 is not cut. As such, fraying of the articular cartilage at a cut edge may be avoided.

In other words, the implant 6700 is mapped and placed within the borders of the existing defect. As such, the portion of the articular surface excised for the implant site has a surface area less than the surface area of the defect. Such an alternative method may be accomplished by any of the variety of methods discussed herein. For instance, one method may include locating the defect in the articular surface, establishing a working axis substantially normal to the articular surface and substantially centered within the defect, excising a portion of the bone surface adjacent to the axis thereby creating an implant site 6711, and installing the implant in the implant site where a least a portion 6707, 6709 of the existing defect is exposed around a perimeter of the defect. Such a method may require measuring down to the exposed subchondral bone, or measuring the articular cartilage surface in closes proximity to the implant site. Of course, a portion of the defect 6707 proximate to the posterior side may, of course, have a different shape or configuration as that portion of the defect 6709 proximate to the anterior side of the implant 6700 when seated.

Turning to Figures 68A-68D, an implant 6800 consistent with the invention may be provided with a feature to promote and encourage remodeling of the articular cartilage onto the proximal surface 6806 of the implant 6800. Such a feature may be an indentation in the proximal surface 6806 of the implant that may be of continuous or noncontiguous shape. In one exemplary embodiment as illustrated in Figures 68A and 68B, the indentations are continuous grooves 6803, 6805, 6807 extending along the proximal surface 6806 of the implant from one side to another. Such grooves 6803, 6805, 6807 may also be provided with thru holes 6809 to communicate to the bone surface. Figure 68B is a cross sectional view of the implant 6800 taken along the line B-B of Figure 68A illustrating the square shaped cross sectional geometry of the exemplary grooves 6803, 6805, 6807.

Turning to Figure 68C, another indentation of the proximal surface 6806 may be one or more spaces 6832, 6834 created at the perimeter edge 6830 of the proximal surface 6806 by the particular geometry of the implant's proximal surface 6806. Such edge spaces 6832, 6834 may also promote and encourage remodeling of the articular cartilage onto the proximal surface 6806 of the implant 6800.

Turning to Figure 68D, a top perspective view of the implant 6800 seated in an articular surface 6816 is illustrated. As illustrated, indentations such as grooves 6803, 6805, 6807 and edge spaces 6832, 6834 may promote remodeling of the articular cartilage such that a portion 6818 of the articular cartilage has extended over the proximal surface 6806 of the implant 6800. This portion 6818 of articular cartilage may only be a superficial layer of cartilage, and may only extend over a portion of the proximal surface 6806 of the implant. However, this remodeling may facilitate load bearing across the transition between the implant 6800 and the surrounding articular cartilage.

Those skilled in the art will recognize that the present invention is subject to other modifications and/or alterations, all of which are deemed within the scope of the present invention, as defined in the hereinafter appended claims.

What is claimed is:

1. A guide device for locating a working axis substantially normal with respect to an articular surface of bone, said device comprising:
 - a shaft having an aiming feature for projecting an axis; and
 - 5 a contact surface comprising a plurality of points radially equidistant from the aiming feature of said shaft.
2. A guide device for locating a working axis substantially normal with respect to a non-spherical articular surface of bone, said device comprising:
 - a first element having a longitudinal axis and a contact surface mounted to a shaft;
 - 10 and
 - a second element with a contact surface movable with respect to the contact surface of the first element, wherein, when said guide device is placed on a non-spherical articular surface, both contact surfaces make contact with said articular surface.
3. A guide device for locating a working axis substantially normal with respect to an articular surface of bone having an anterior-posterior (AP) curve and a medial-lateral (ML) curve, said device comprising:
 - a cannulated outer shaft, said outer shaft having a central longitudinal axis and an outer component at its distal end, said outer component comprising a set of arms; and
 - a cannulated inner shaft slidably disposed within the cannula of said outer shaft, said inner shaft having an inner component at its distal end and sharing the central longitudinal axis of said outer shaft, said inner component comprising a set of arms.
 - 20
4. A method for replacing a portion of an articular surface of bone, said method comprising:
 - establishing a working axis substantially normal to an articular surface of bone;
 - 25 excising only a portion of said articular surface adjacent said axis, thereby creating an implant site; and
 - installing an artificial implant into said implant site.
5. A method for replacing a portion of an articular surface of bone, said method comprising:
 - 30 establishing a working axis substantially normal to an articular surface of bone;
 - excising only a portion of said articular surface adjacent said axis, thereby creating an implant site;
 - selecting an implant corresponding to the dimensions of said implant site from a set of variously-sized implants; and

installing said selected implant into said implant site.

6. A method for replacing a portion of an articular surface of bone generally defined by a first and a second curve, said method comprising:

establishing an axis generally normal to the portion of an articular surface of bone to
5 be replaced based on a first curve and a second curve of said articular surface;

excising only a portion of said articular surface adjacent said axis, thereby creating an
implant site;

fabricating an artificial implant corresponding to the dimensions of said implant site;
and

10 installing said artificial implant into said implant site.

- 7. A method for replacing a portion of an articular surface of bone generally defined by a first and a second curve, said method comprising:

establishing an axis generally normal to the portion of an articular surface of bone to
be replaced based on a first curve and a second curve of said articular surface;

15 excising only a portion of said articular surface adjacent said axis, thereby creating an
implant site;

selecting from a set of variously-sized artificial implants an artificial implant
corresponding to the dimensions of said implant site; and

installing said selected implant into said implant site.

20 8. A tool for removing an implant from its delivery site, said tool comprising:

an element with a generally leading edge and a barb element disposed proximally to
the leading edge; and

at least one structural element that creates sufficient bias of the leading edge of the
tool to rigidly couple to a surface of the implant to be removed.

25 9. A tool for removing an implant from its delivery site, said tool comprising:

a cylindrical structure having an end; said end comprising a longitudinal central axis,
a circular blade portion having a leading edge comprising a blade surface turned on the distal-
most portion, and a lip portion disposed proximally with respect to the leading edge; and

30 a plurality of slits parallel to the longitudinal central axis of said end formed along the
length of said cylindrical structure, so as to permit sufficient outward expansion of the distal
end to accommodate the top edge of an implant therein.

10. A method for removing an implant from its delivery site, said method
comprising:

disposing the lip portion of the leading edge of the end of a removal tool over the upper edge of an implant seated in its delivery site; and applying a pulling force to said removal tool.

11. A device for measuring a portion of an articular surface of bone, said device comprising:

5 a handpiece;
a shaft disposed within said handpiece, said shaft comprising a feature for aligning with a working axis or mating to a fixed element;
a contact tip moveably coupled to said shaft; and
10 at least one measuring element coupled to said contact tip or said shaft.

12. A device for mapping a portion of an articular surface of bone, said device comprising:

a handpiece;
an inner shaft running along the length of and disposed within said handpiece, said
15 inner shaft comprising a mating feature for mating with a fixed element located substantially normal with respect to an articular surface;
a contact tip slidably and rotatably disposed about said inner shaft;
a rotary measuring element coupled to and rotating with said contact tip; and
a linear measuring element nested concentrically and coaxially to said rotary
20 measuring element, and coupled to and moving linearly with said contact tip.

13. A set of guide devices for locating a working axis substantially normal with respect to an articular surface of bone or for determining the dimension of an implant to be installed in an articular surface of bone, said set comprising:

a plurality of variously dimensioned guide devices, each said guide device having a
25 handling tab or shaft and a contact surface; said contact surface comprising a plurality of points radially extending from said handling tab or shaft; wherein, when at least one said guide device is placed on an articular surface, said contact surface makes contact with said articular surface, and said plurality of points of said contact surface surrounds a defect in said articular surface.

30 14. An implant, comprising:

a bone-facing distal surface;
a proximal surface; and
a protrusion formed by an extension of said bone-facing distal surface and said proximal surface.

15. An implant for installation into a portion of an articular surface, said implant comprising:

a bone-facing distal surface configured to mate with an implant site created by excising a portion of said articular surface;

5 a proximal surface having a contour based on an original surface contour of said excised portion of said articular surface; and

a cavity configured to allow an un-excised portion of said articular surface proximate to said implant to remodel over a perimeter edge of said proximal surface.

16. An implant for installation into a portion of an articular surface having an anterior portion, a posterior portion, a medial portion and a lateral portion, said implant comprising:

a bone-facing distal surface configured to mate with an implant site created by excising a portion of said articular surface; and

15 a proximal surface having a contour based on an original surface contour of said excised portion of said articular surface, and at least two side surfaces each having a concentric arcuate shape with a common center, wherein said implant has an elongate arcuate geometric shape.

17. A method for replacing a portion of an articular surface of bone, said method comprising:

20 establishing a working axis substantially normal to an articular surface of bone;

excising a portion of said articular surface adjacent to said axis, thereby creating an implant site, said implant site having a first and second opposing arcuate shaped sides; and installing an implant to said implant site.

18. A method of replacing a portion of an articular surface of bone, said method comprising:

25 locating an existing defect in said articular surface;

establishing a working axis substantially normal to said articular surface and substantially centered with said existing defect;

30 excising a portion of said articular surface adjacent to said axis, thereby creating an implant site; and

installing an implant in said implant site, wherein at least a portion of said existing defect is exposed around a perimeter of said implant.

19. An implant for installation into a portion of an articular surface, said implant comprising:

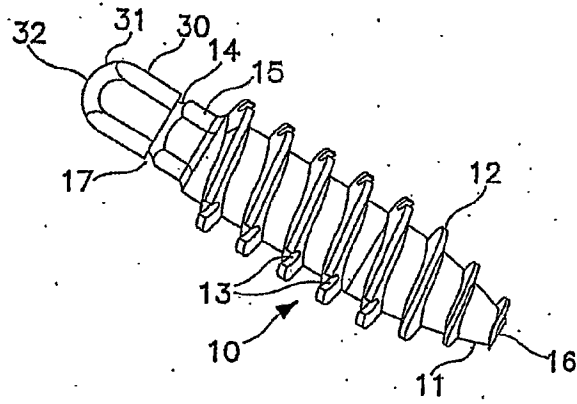

FIG. 3a

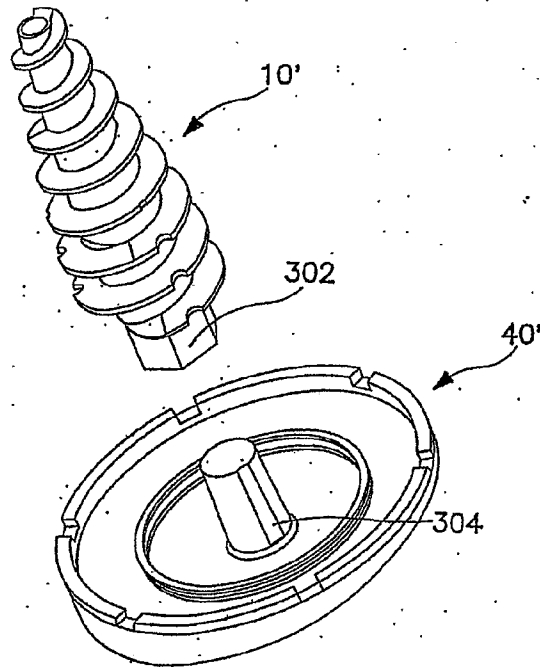

FIG. 3b

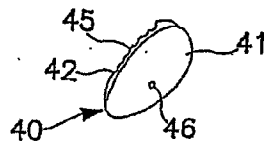

FIG. 4a

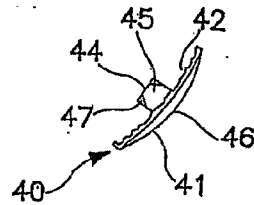

FIG. 4b

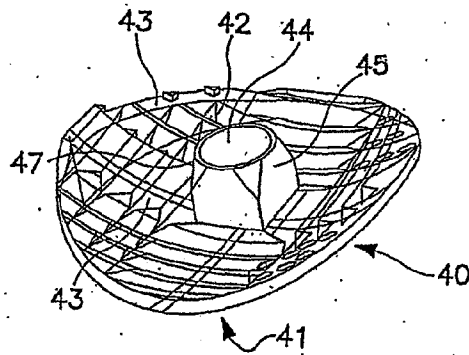

FIG. 4c

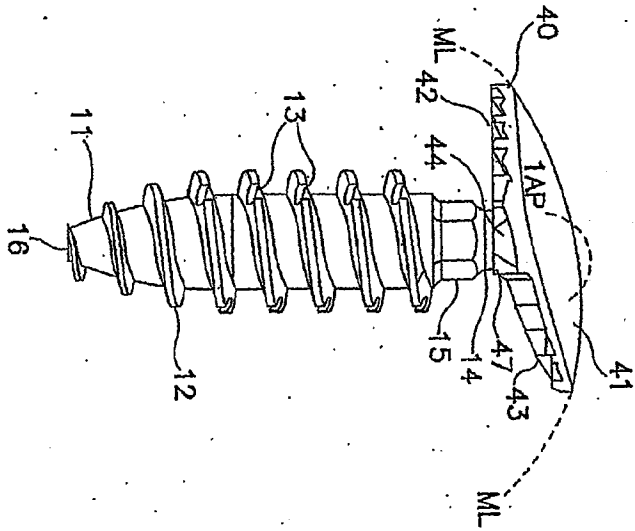

FIG. 5a

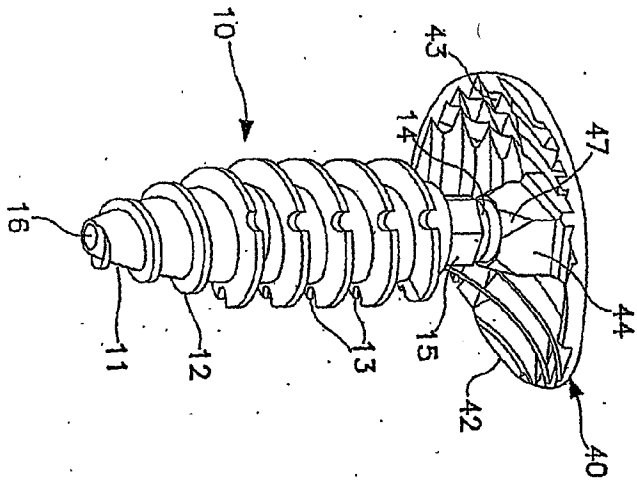

FIG. 5b

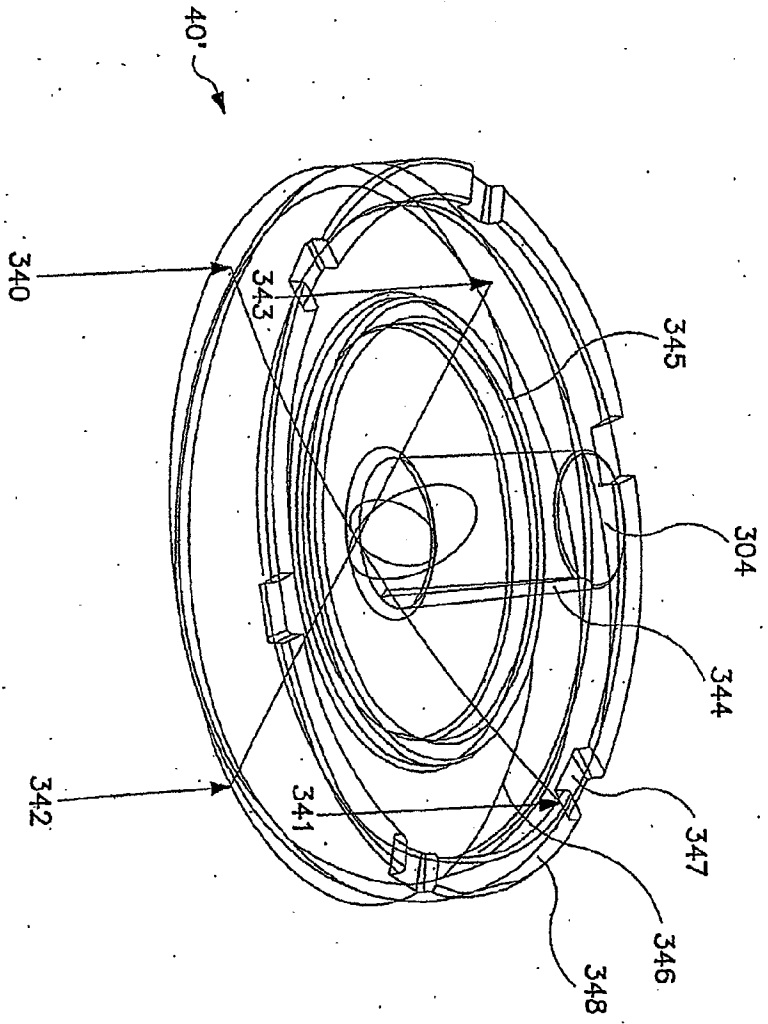

FIG. 5c

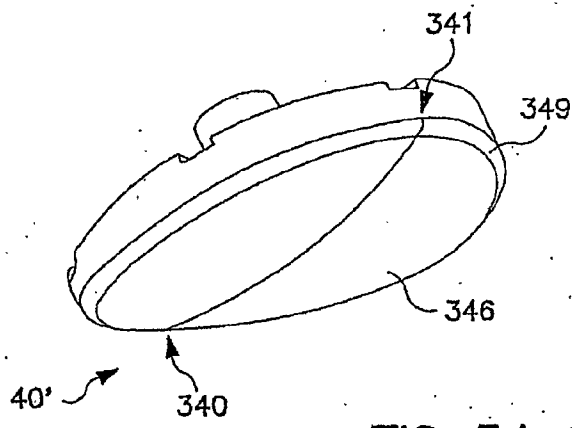

FIG. 5d.

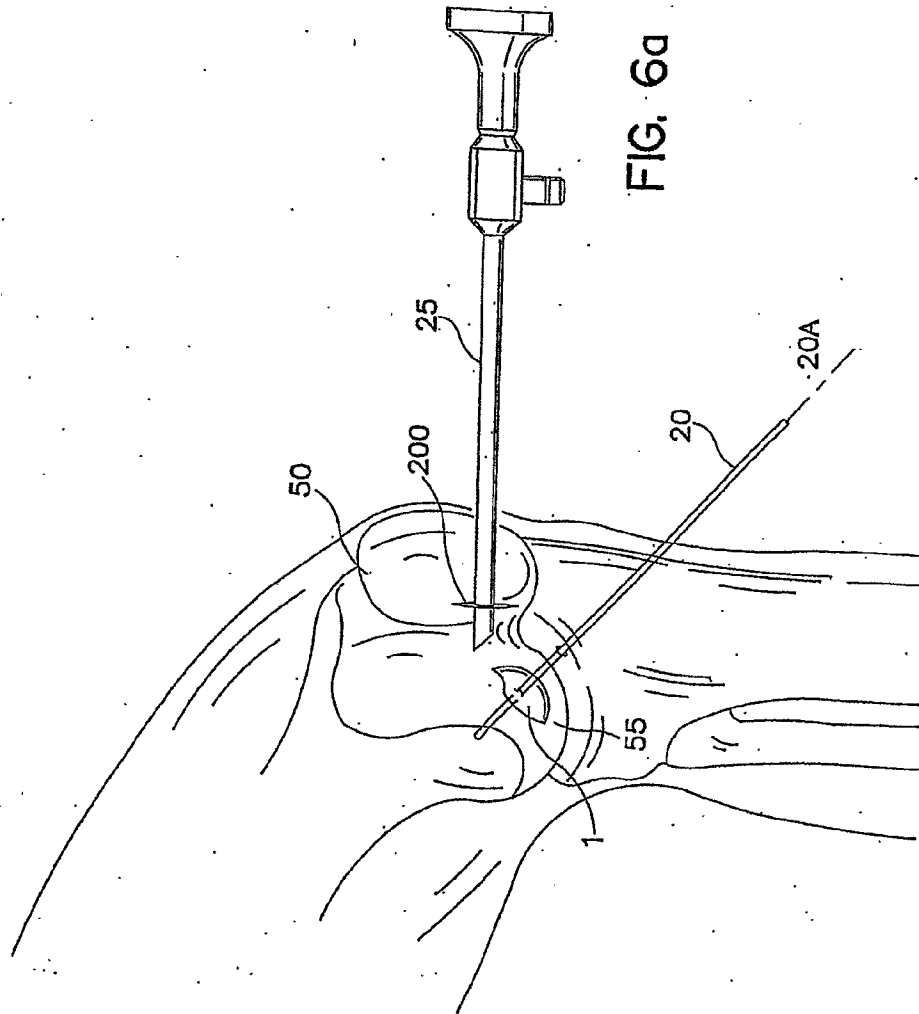

FIG. 6a

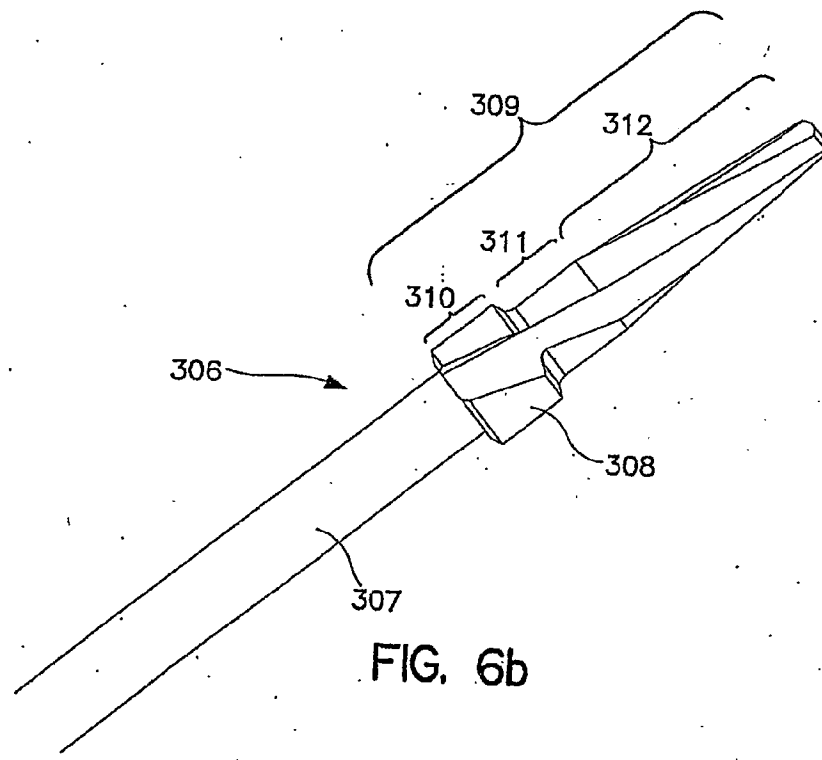

FIG. 6b

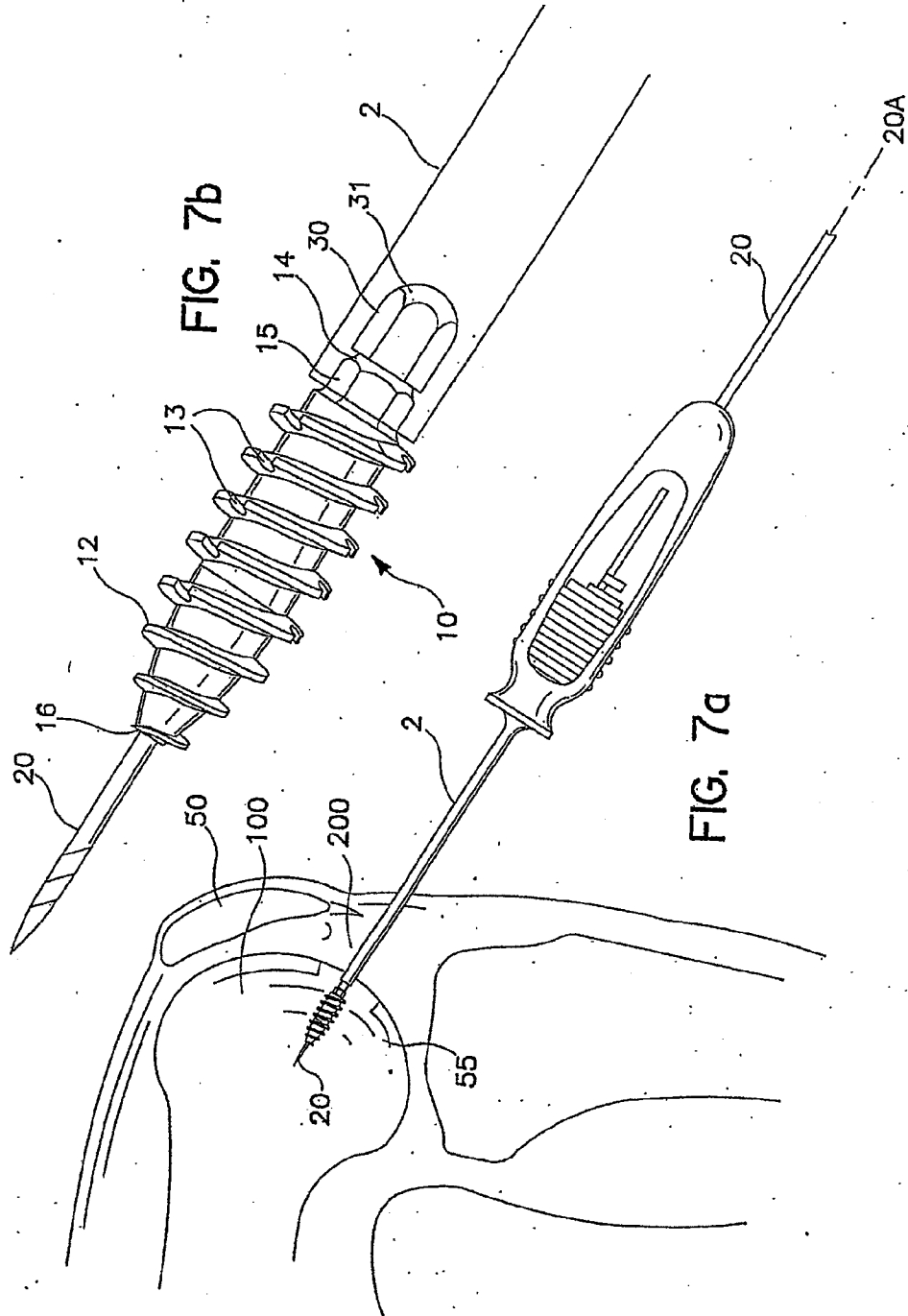

FIG. 7b

FIG. 7a

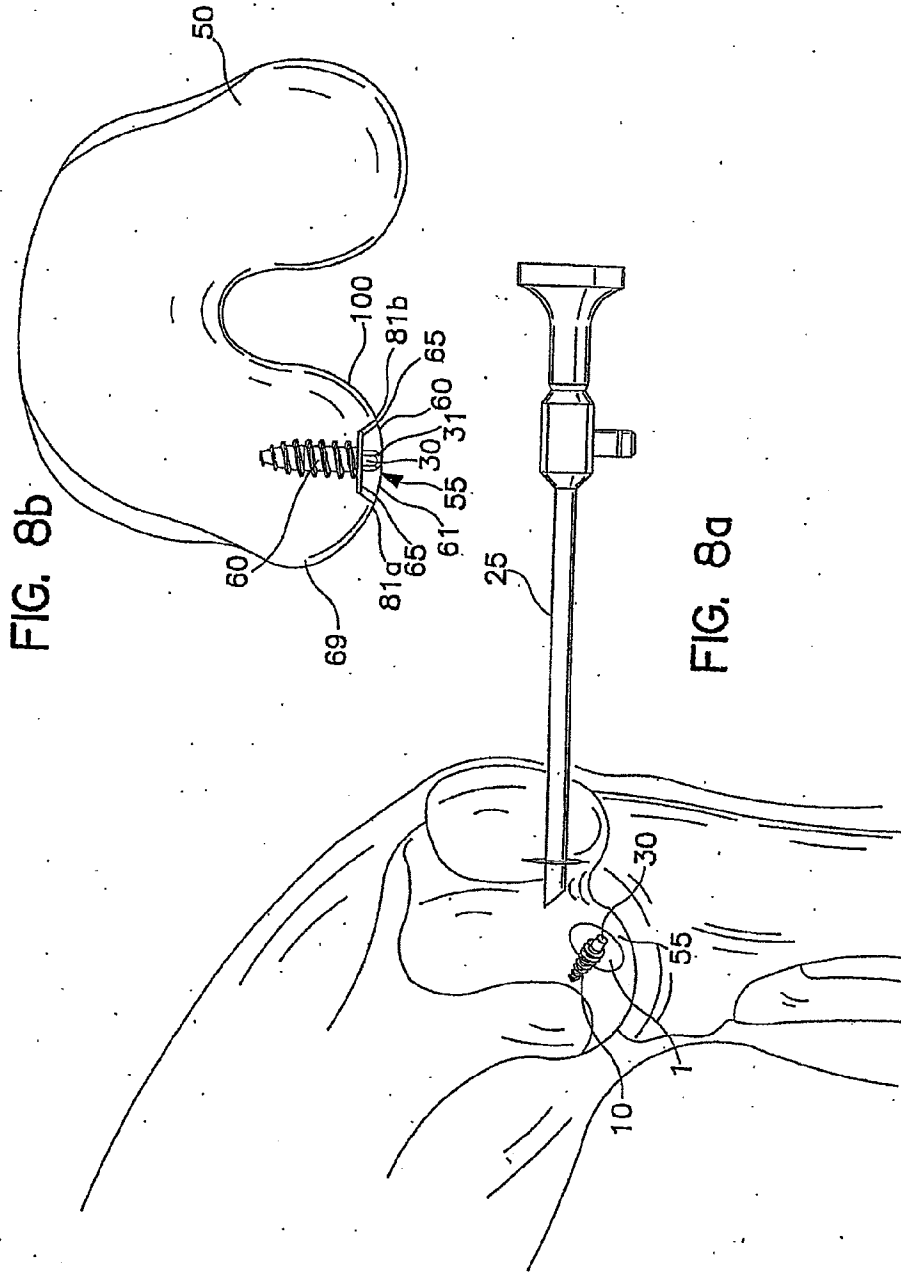

FIG. 8b

FIG. 8a

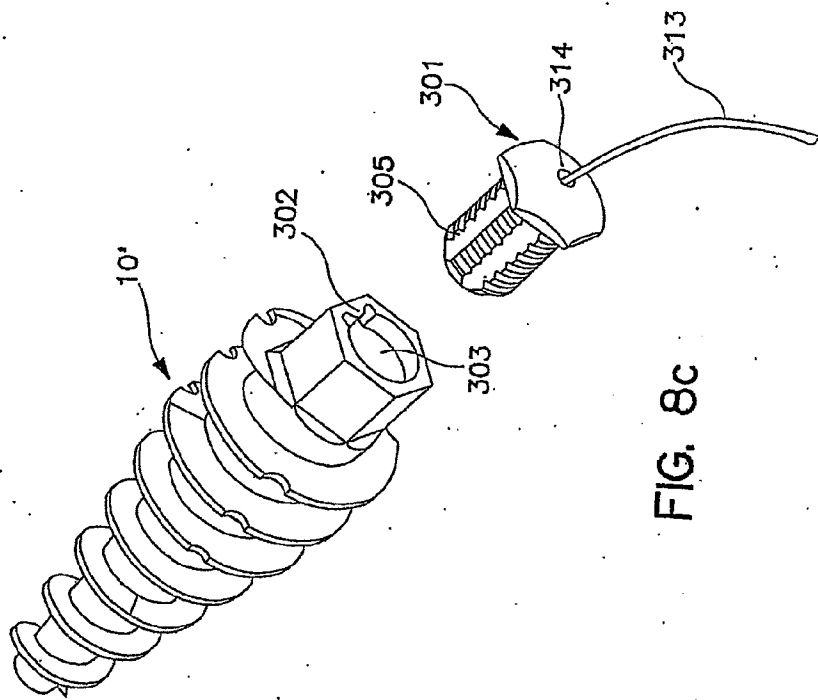

FIG. 8c

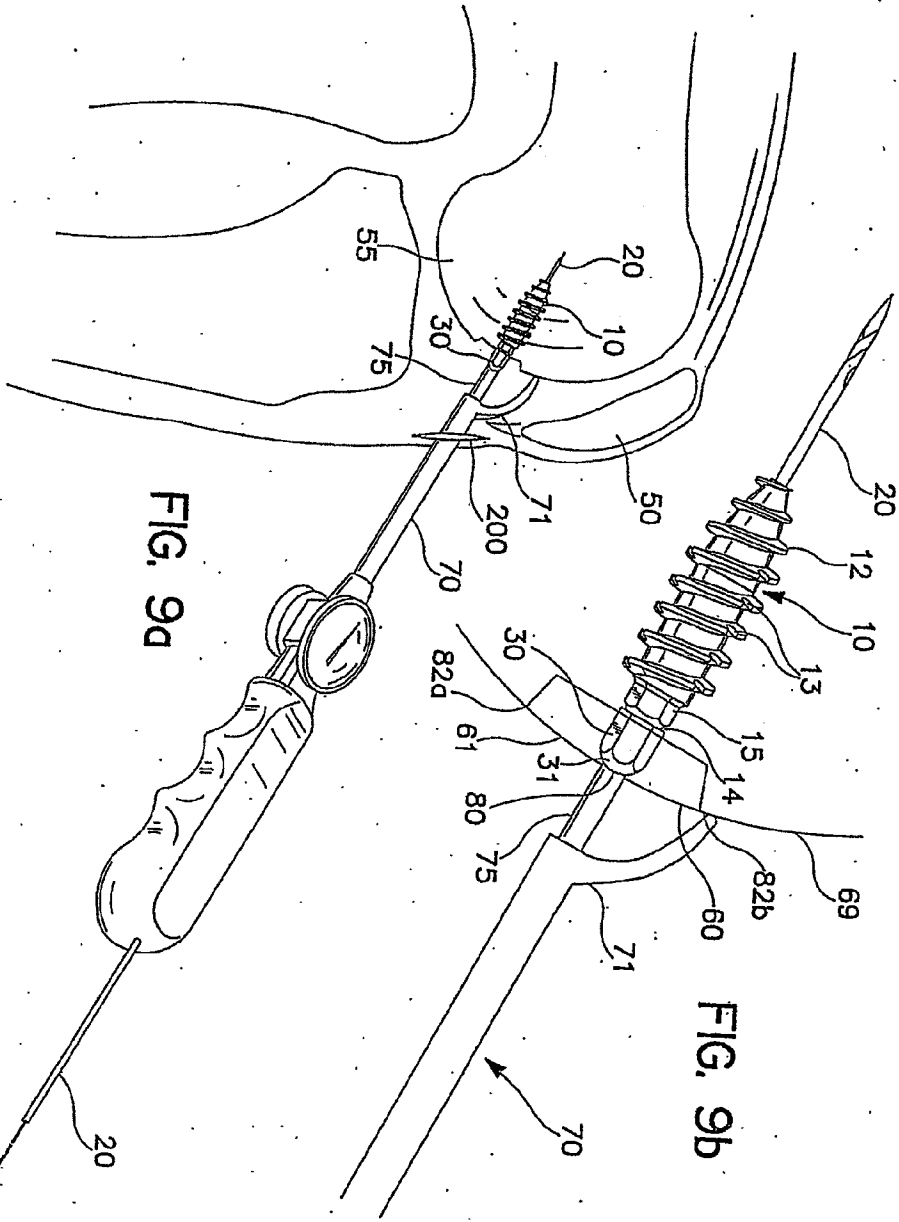

FIG. 9a

FIG. 9b

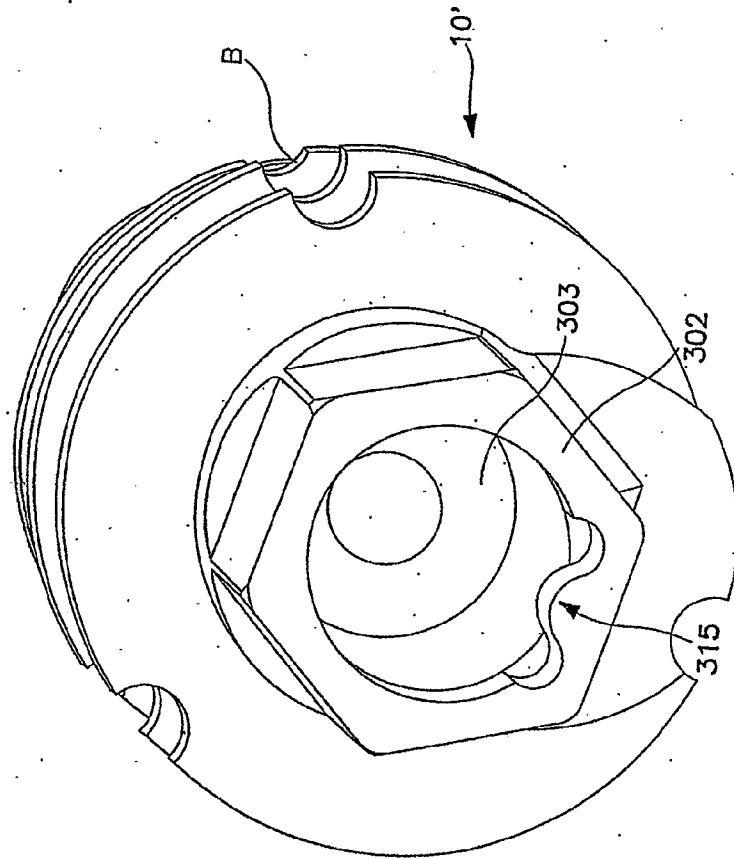

FIG. 9c

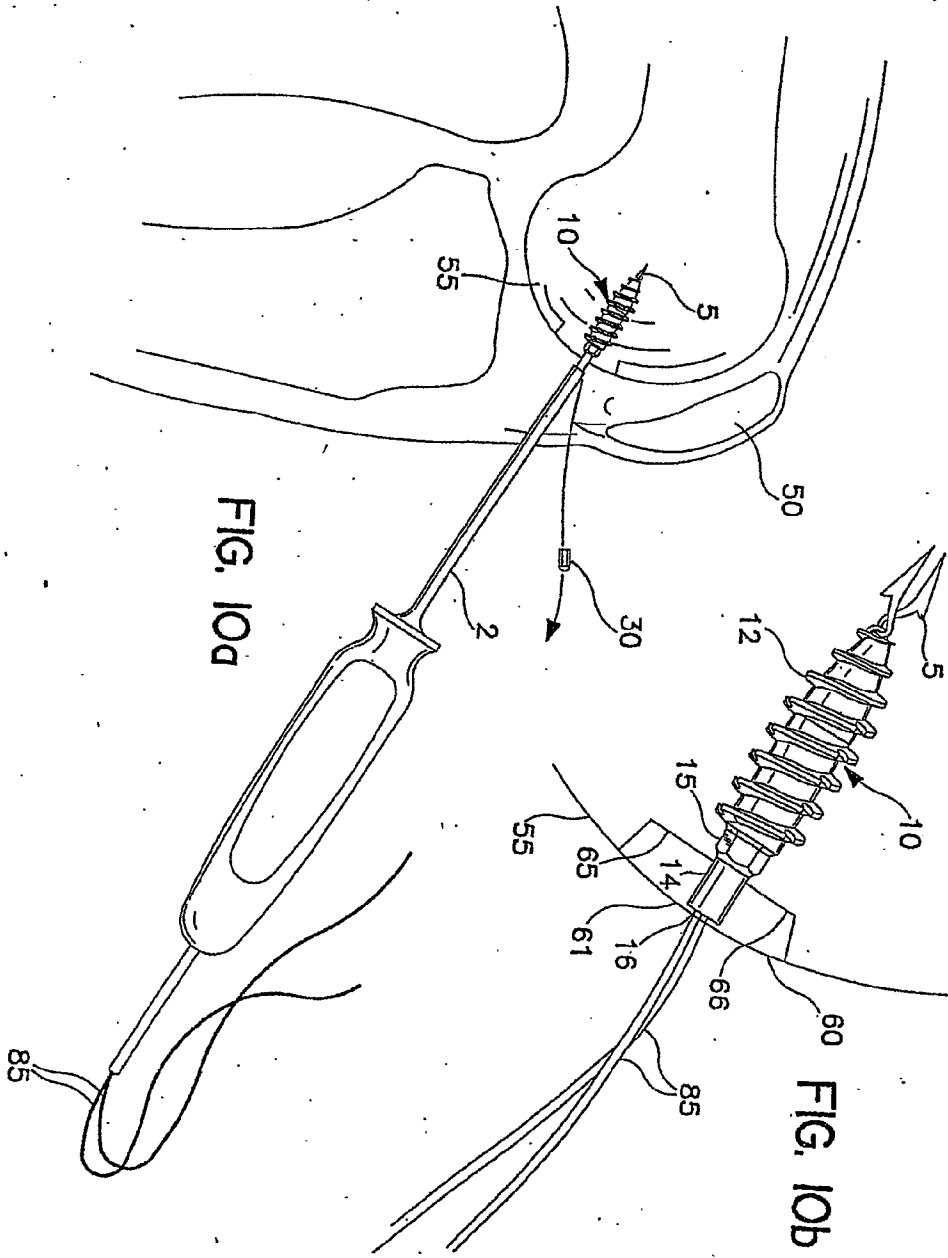

FIG. 10A

FIG. 10B

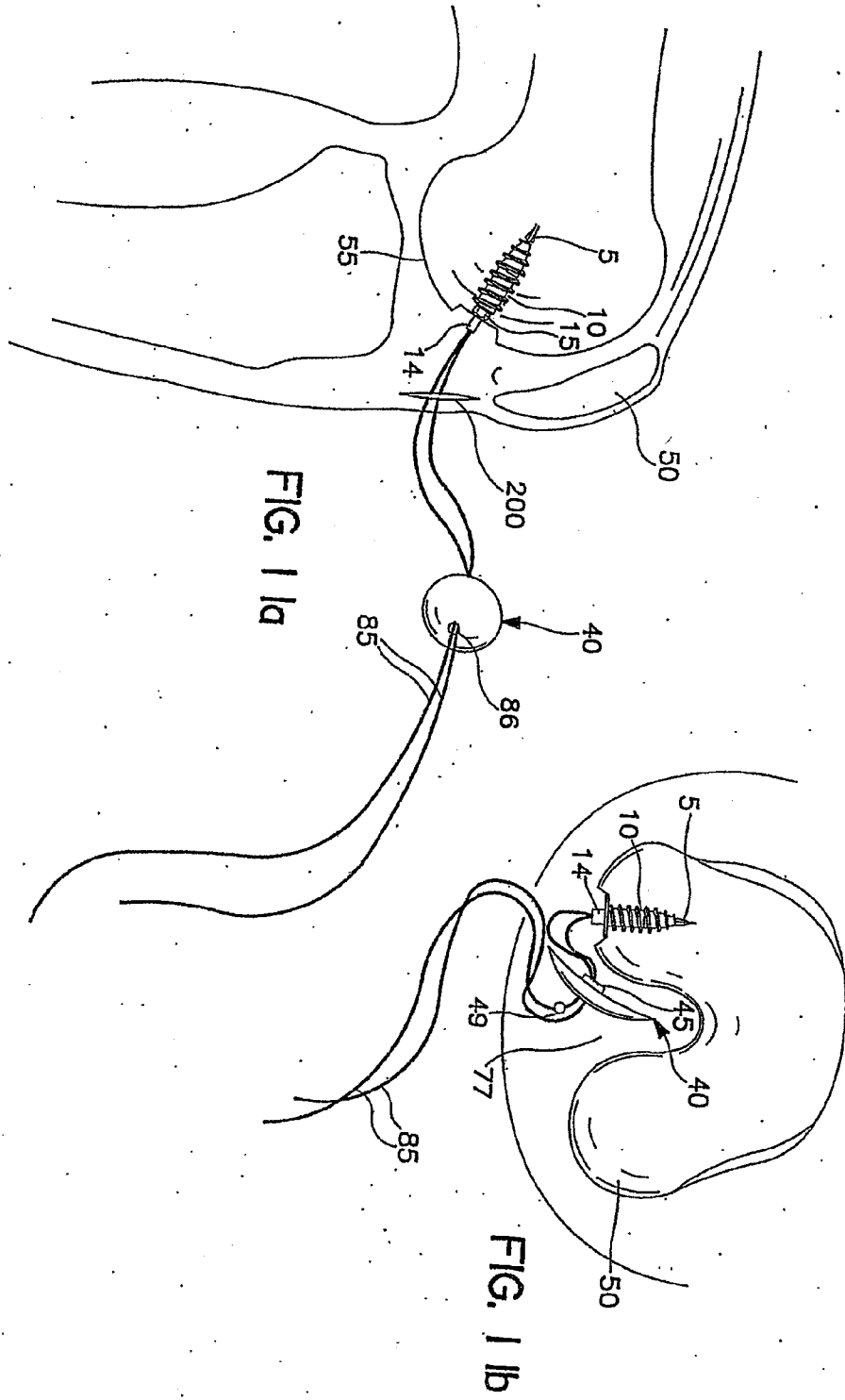

FIG. 1 la

FIG. 1 lb

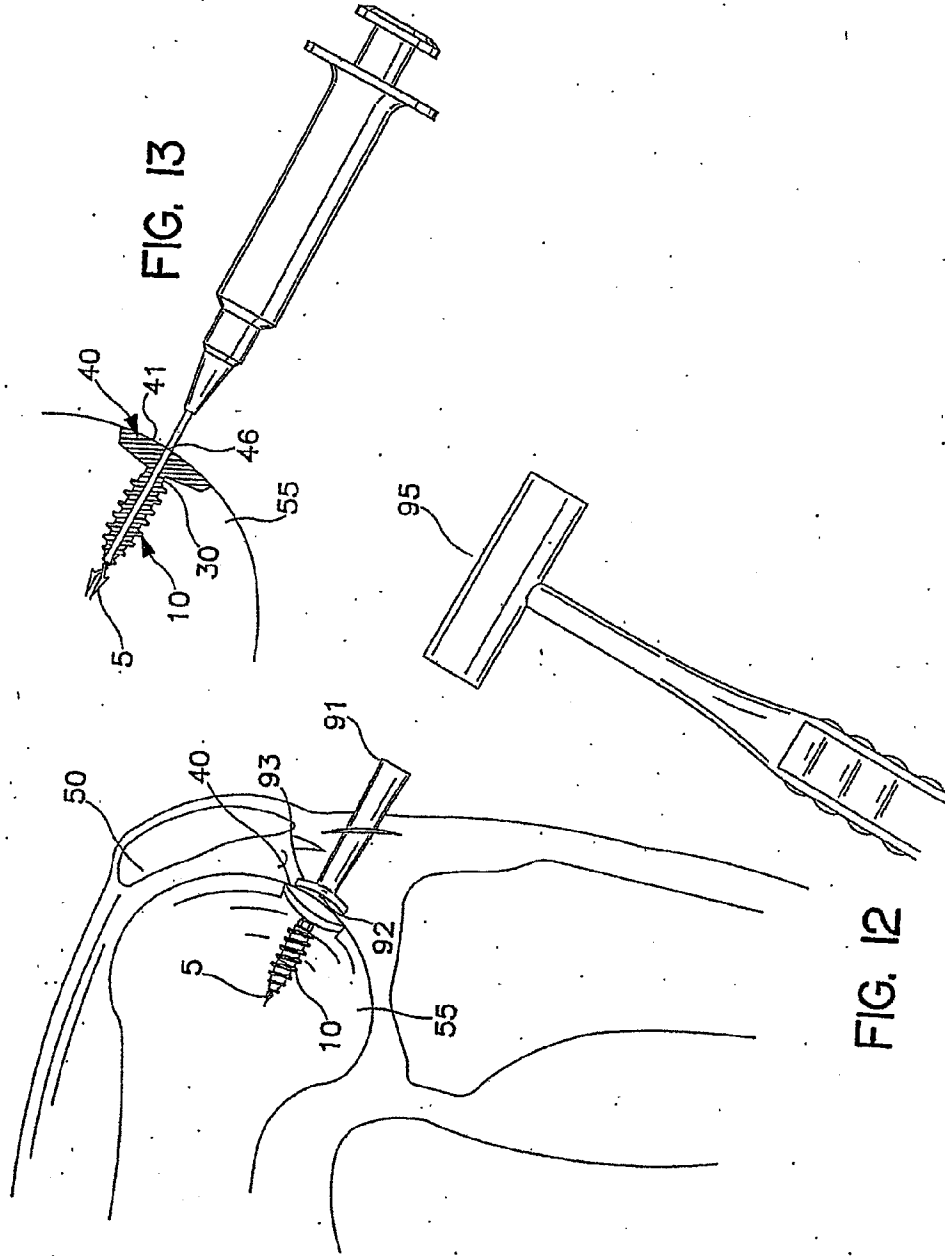

FIG. 13

FIG. 12

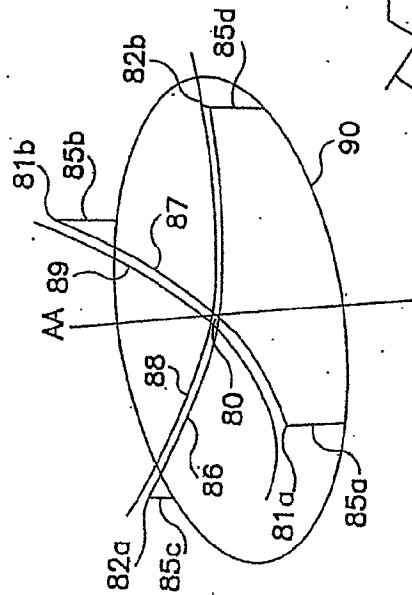

FIG. 14a

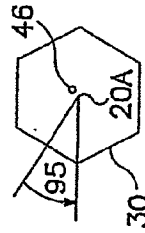

FIG. 14b

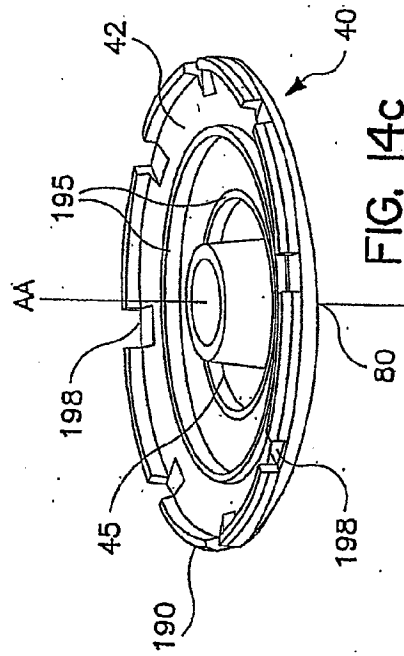
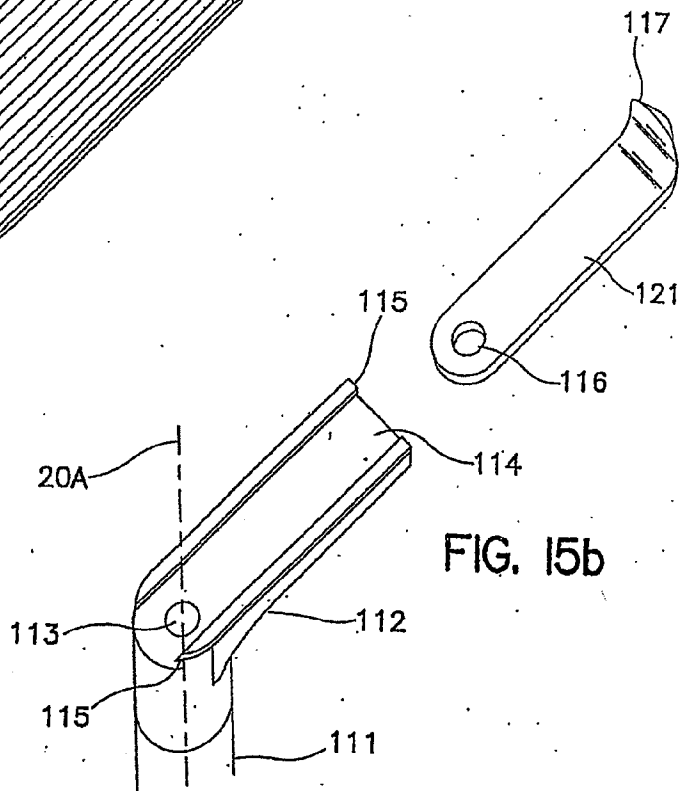
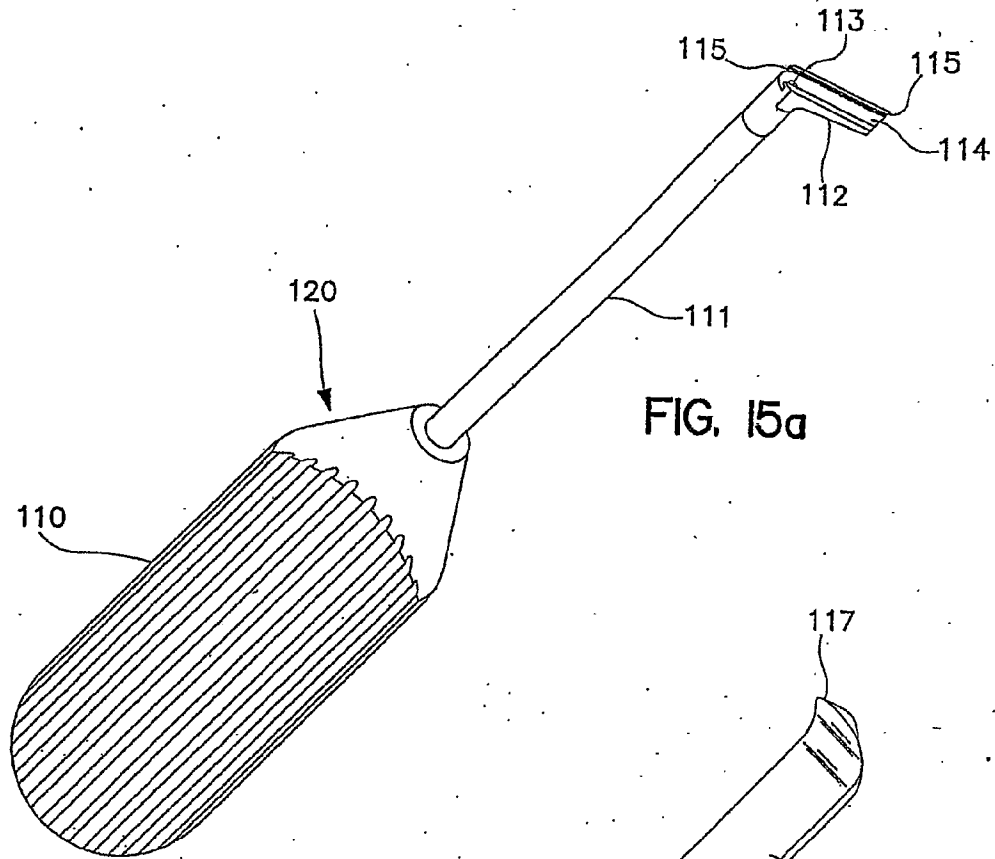
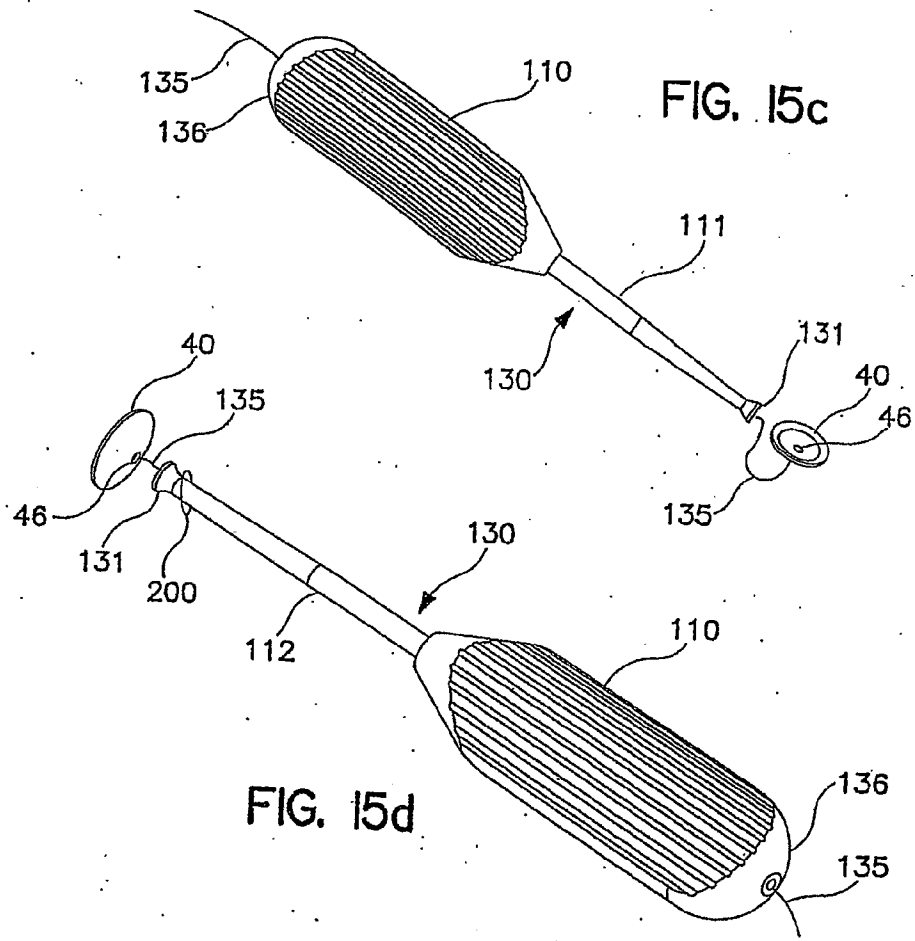

FIG. 14c





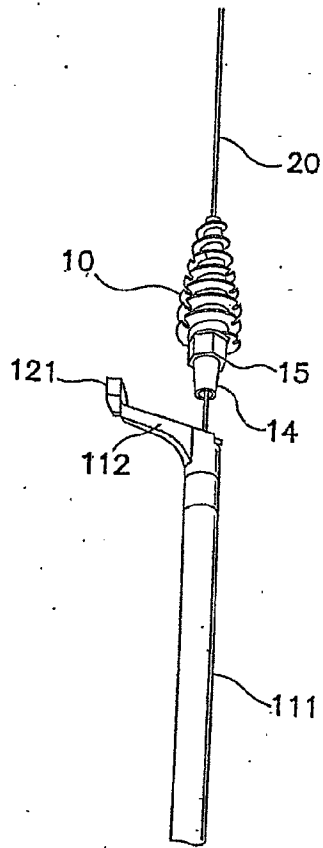

FIG. 16

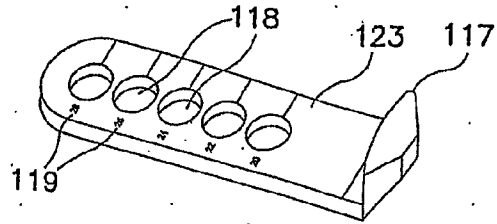

FIG. 17a

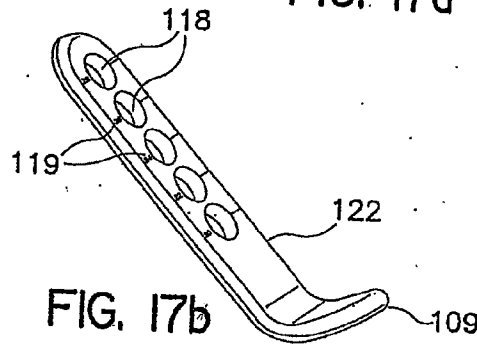

FIG. 17b

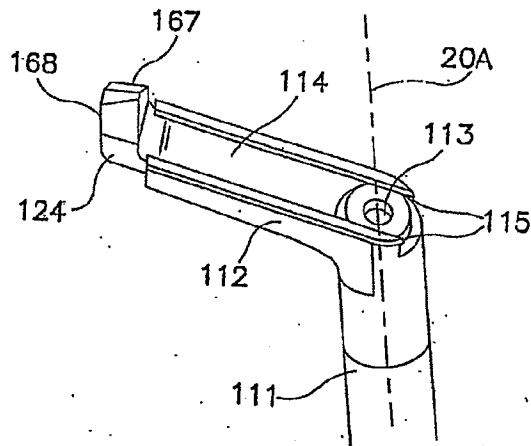

FIG. 17c

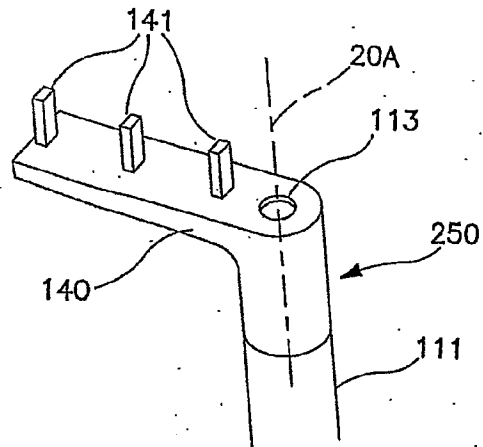

FIG. 18a

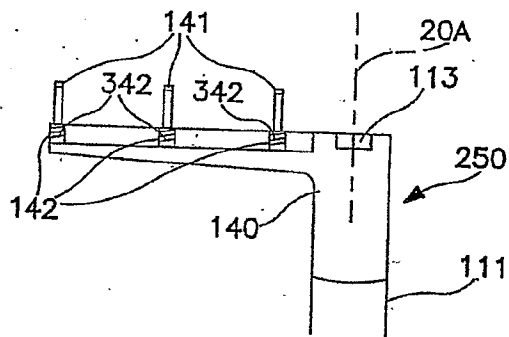

FIG. 18b

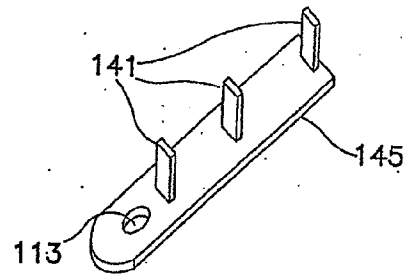

FIG. 18c

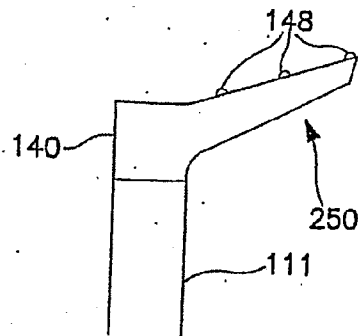

FIG. 18d

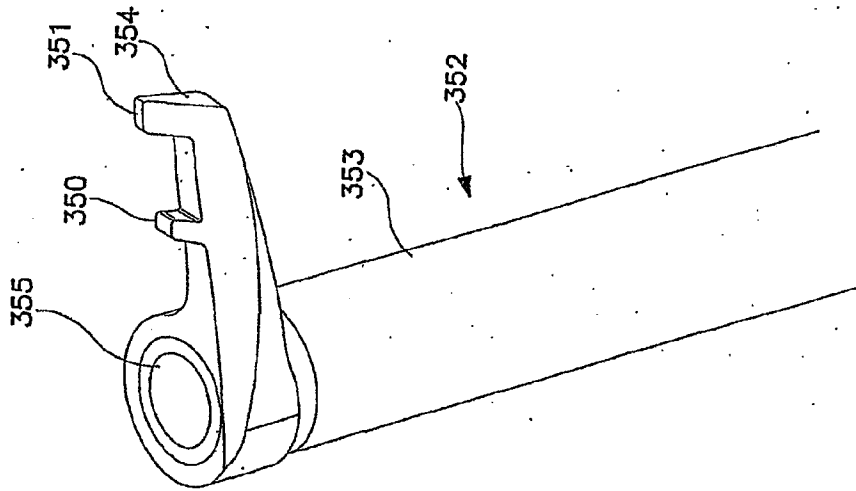

FIG. 18e

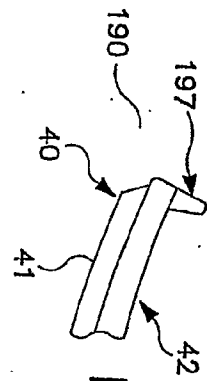

FIG. 19b

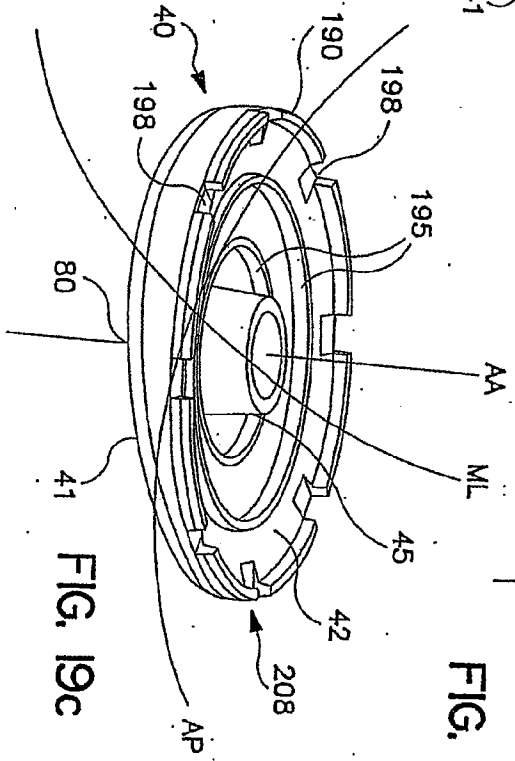

FIG. 19c

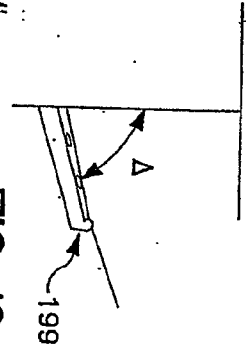

FIG. 19d

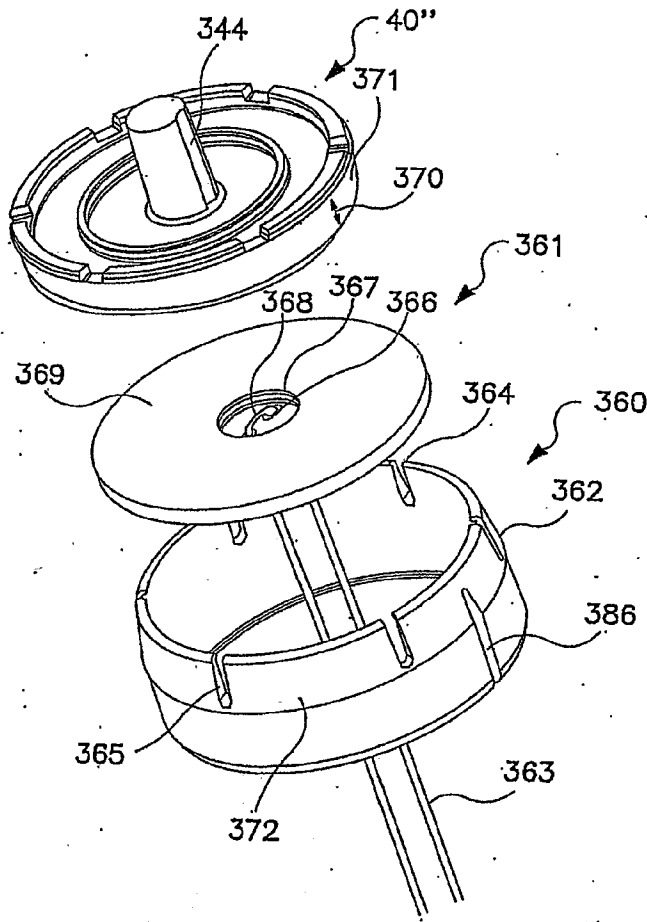

FIG. 19d

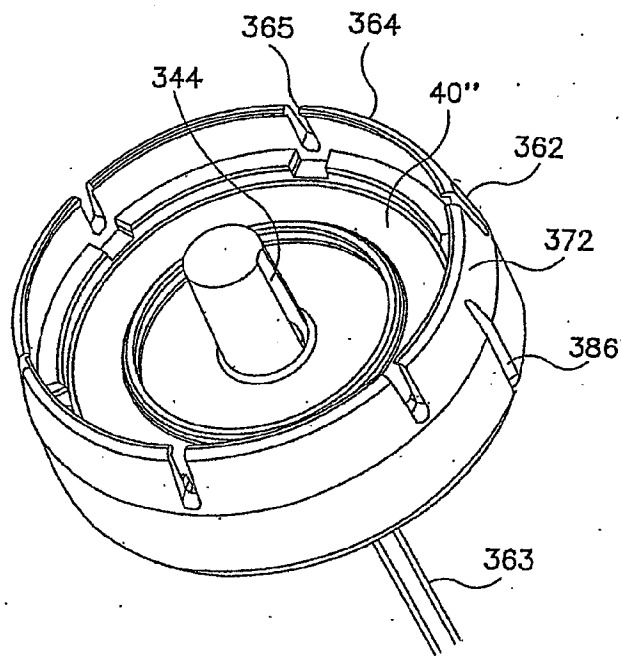

FIG. 19e

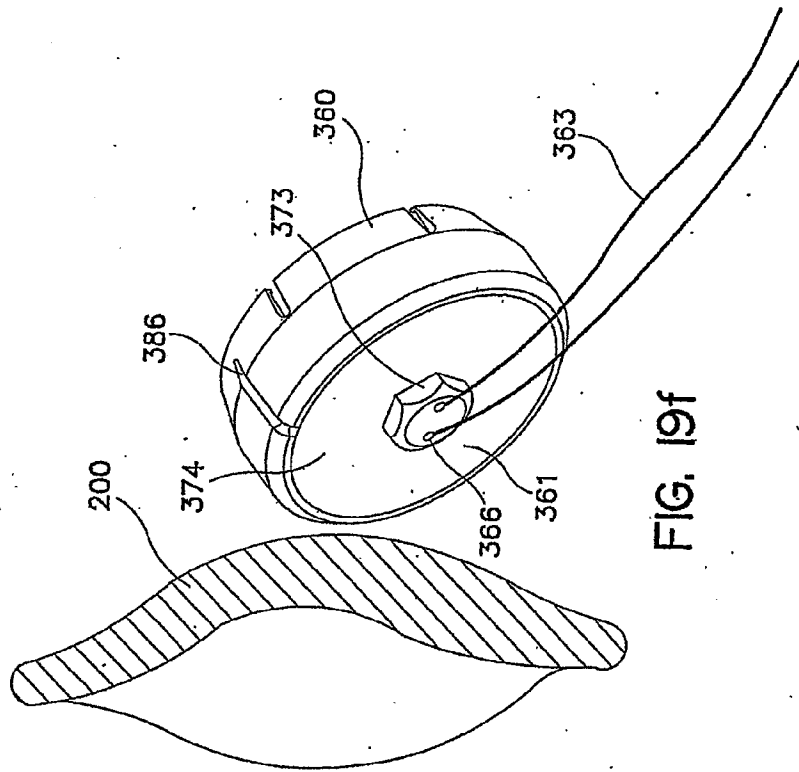
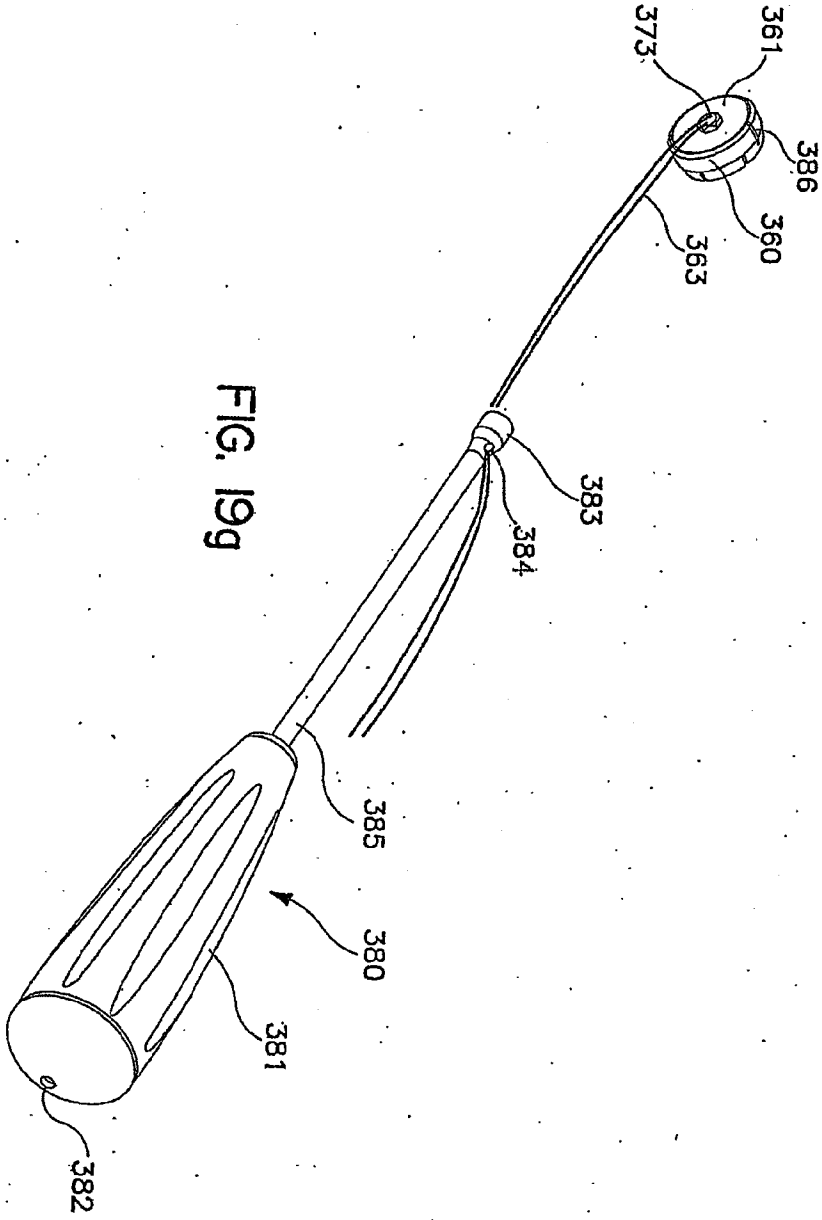

FIG. 19f



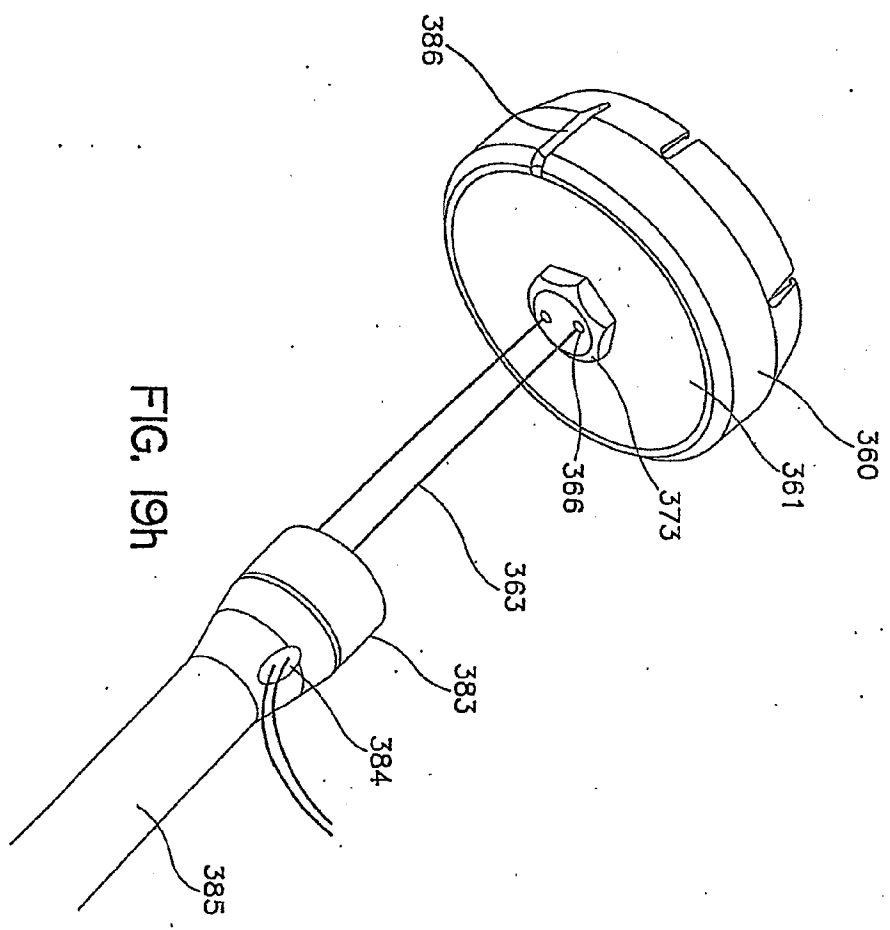

FIG. 19h

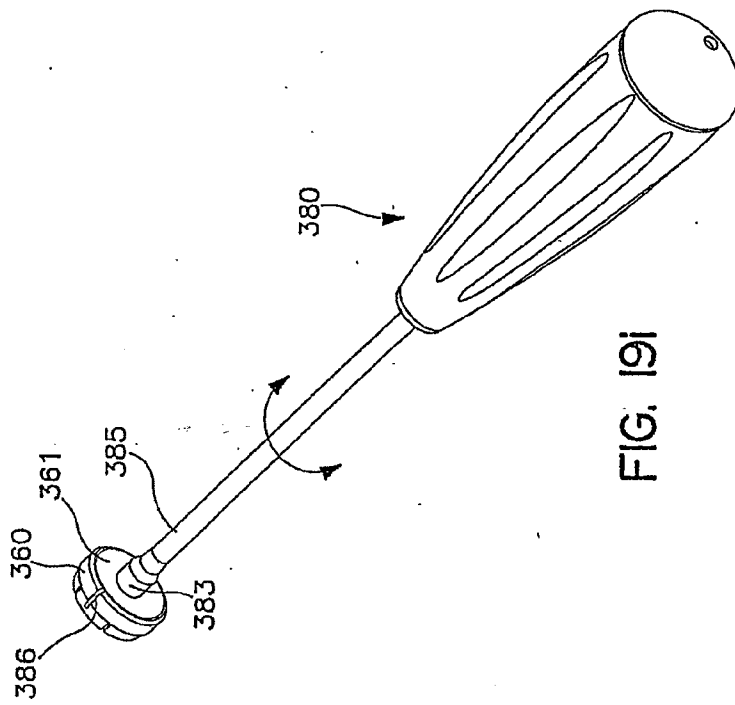
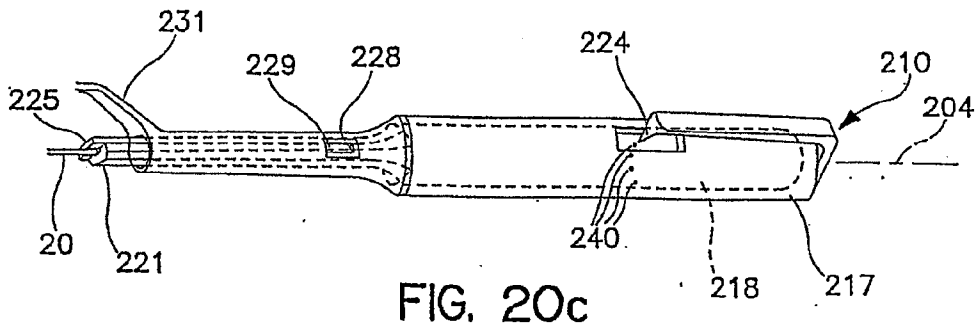
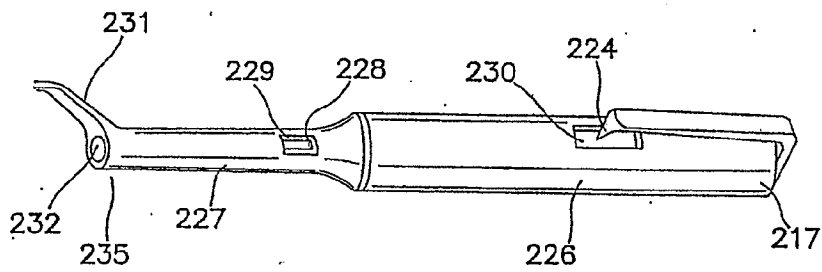
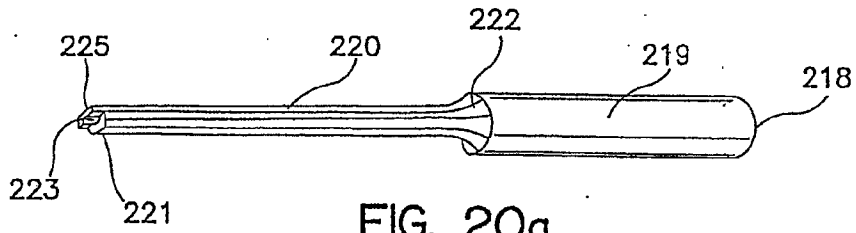
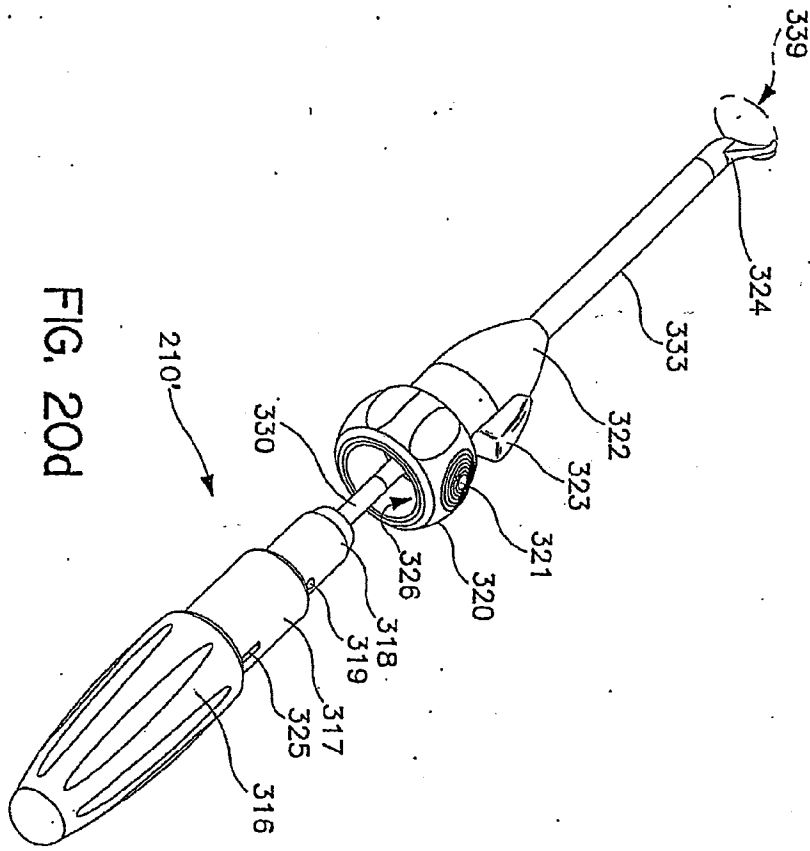

FIG. 191





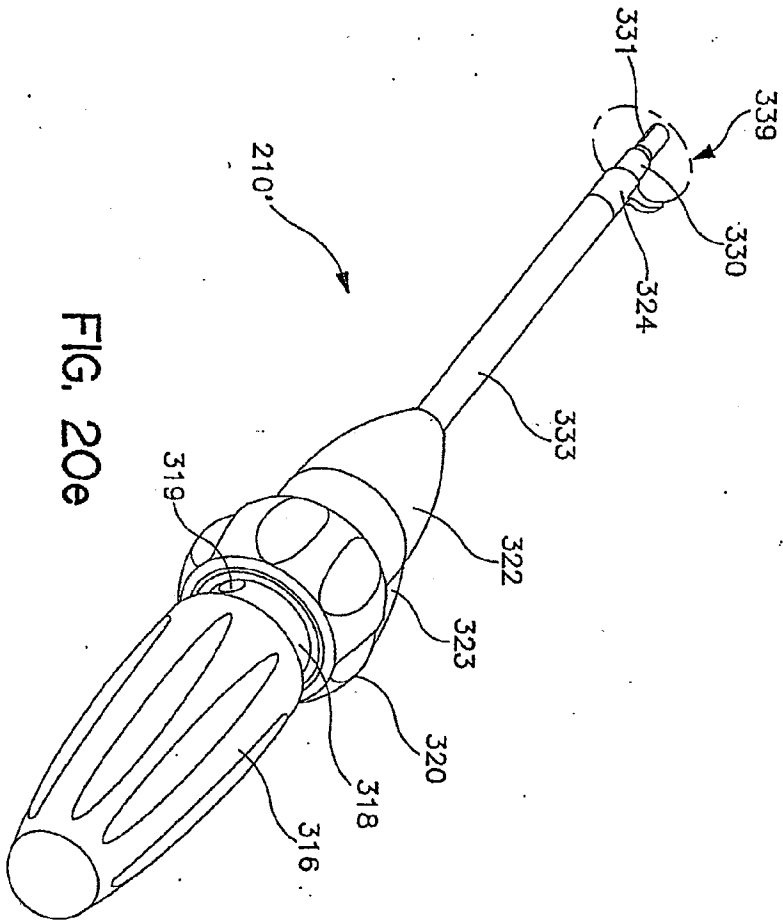

FIG. 20e

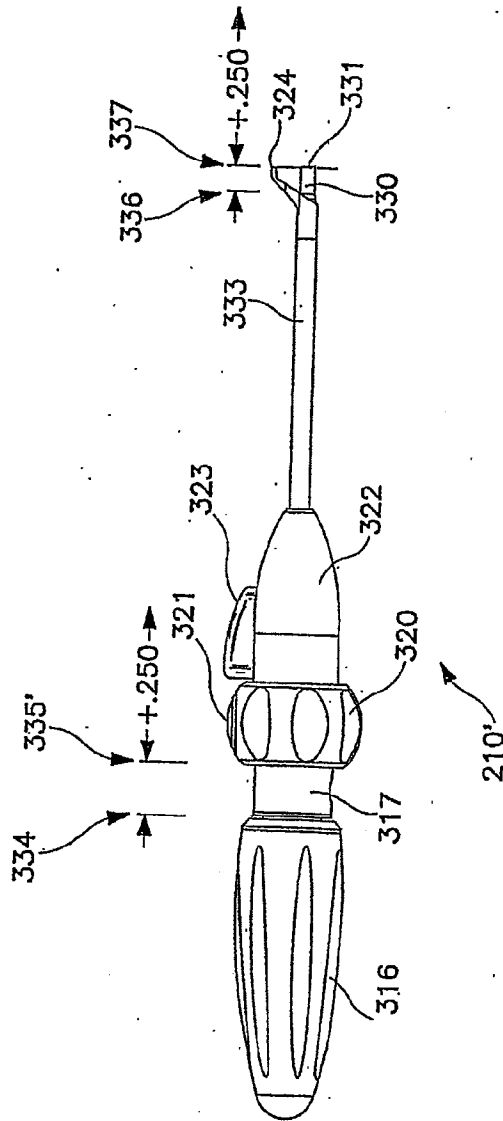

FIG. 20g

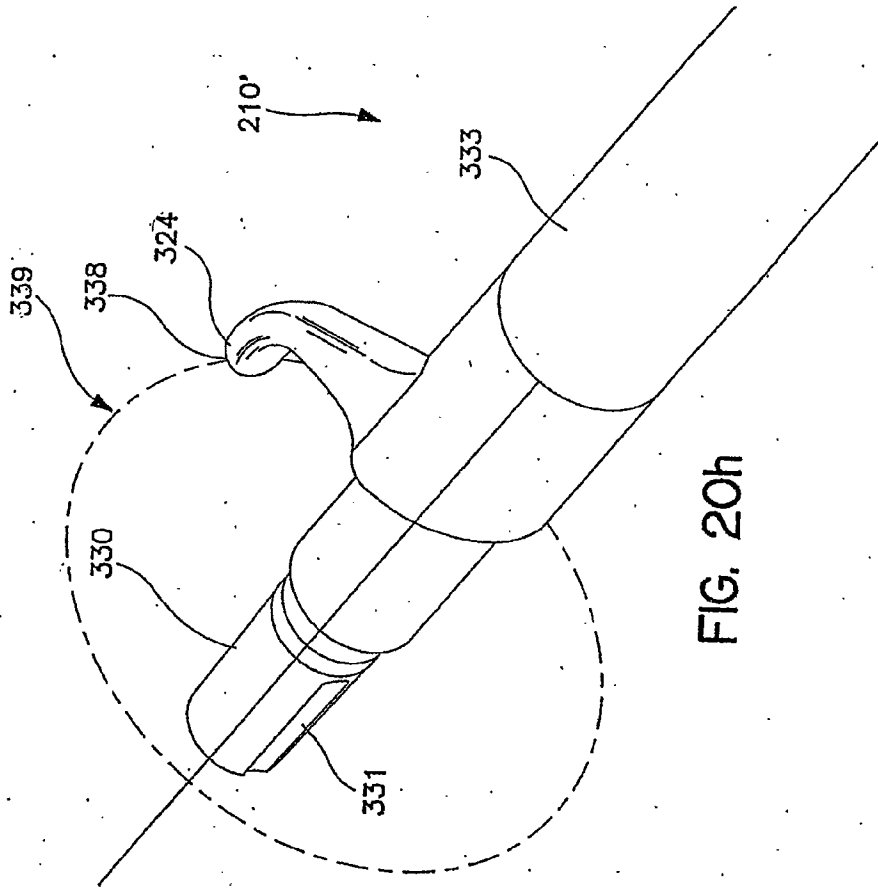

FIG. 20h

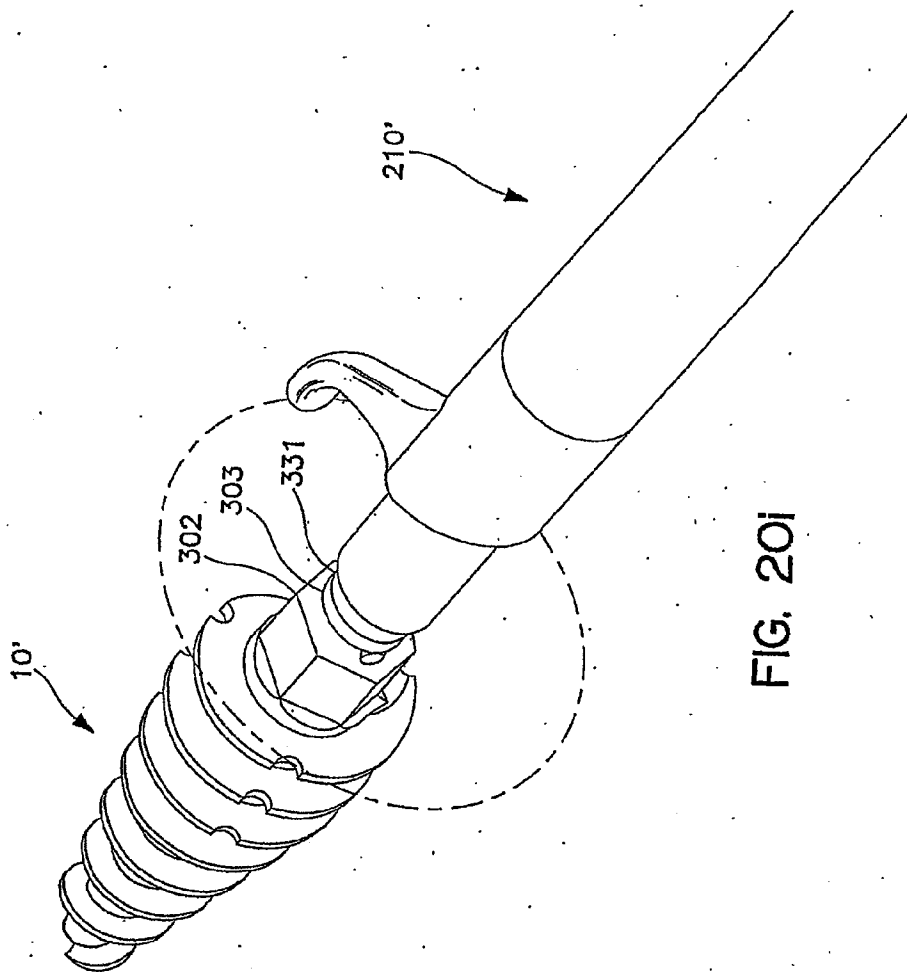

FIG. 20i

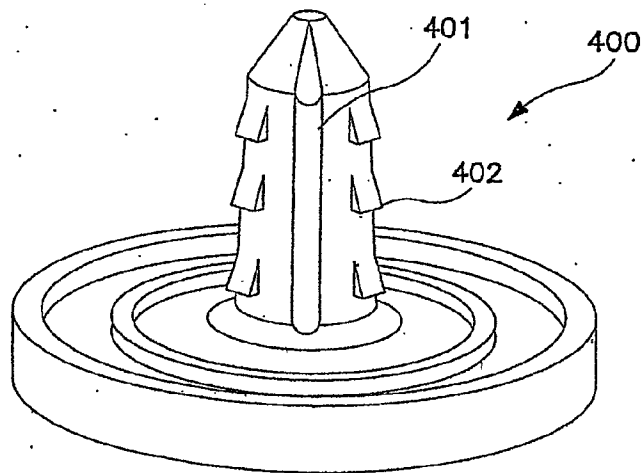

FIG. 21

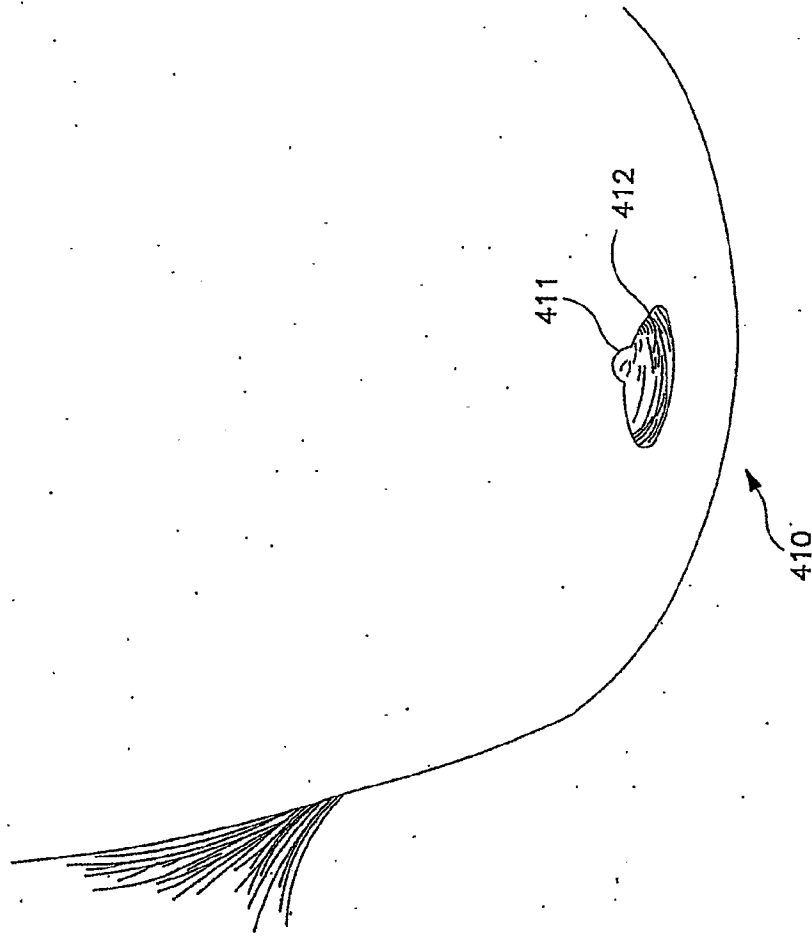

FIG. 22

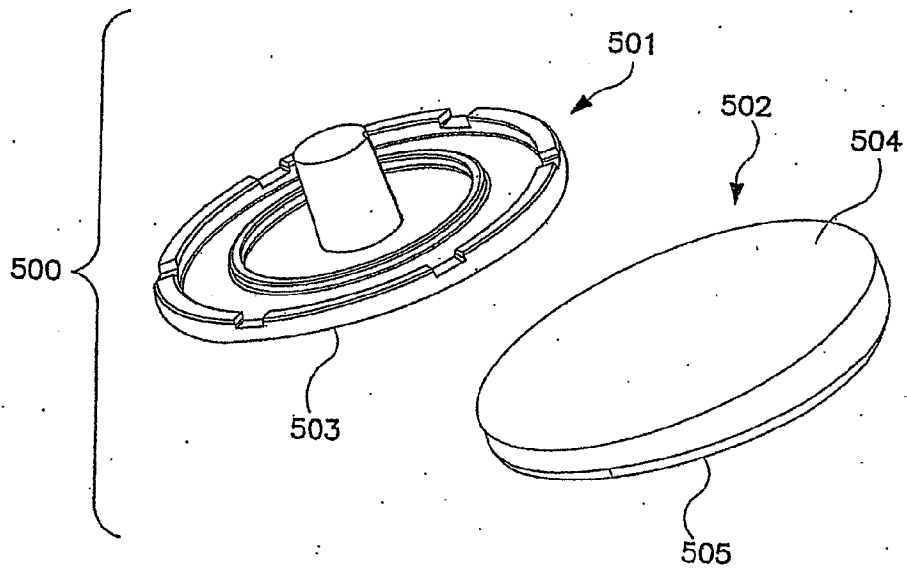

FIG. 23

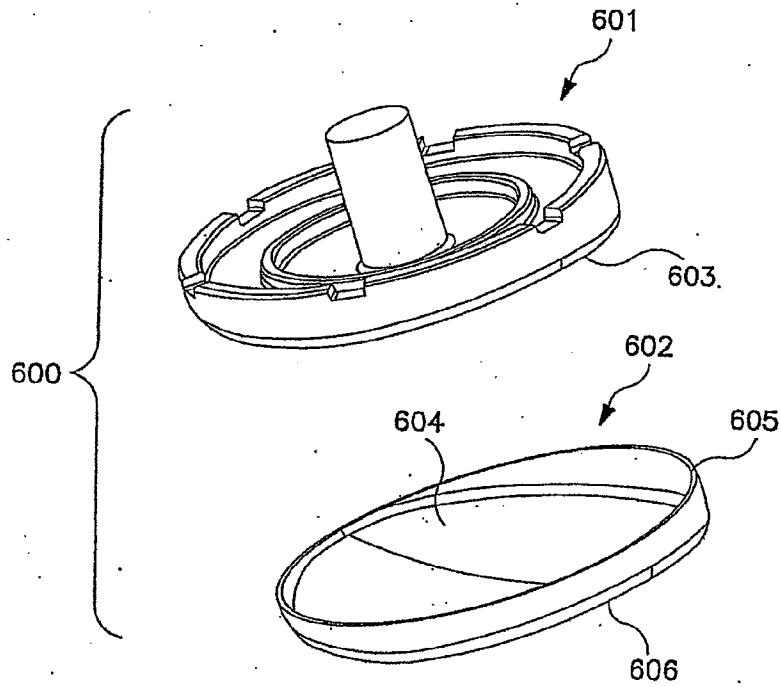

FIG. 24

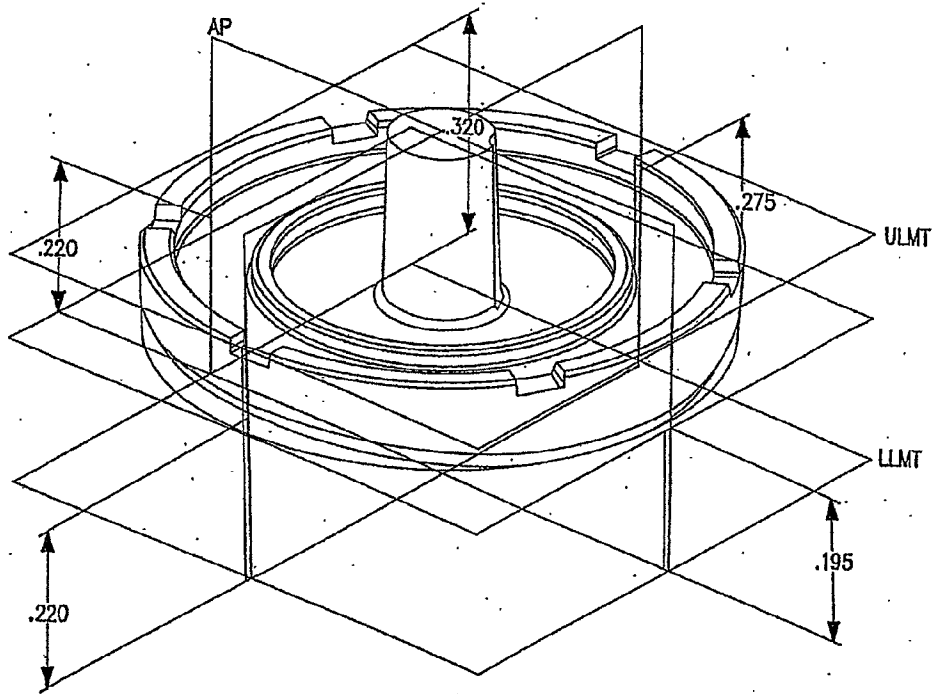

FIG. 25

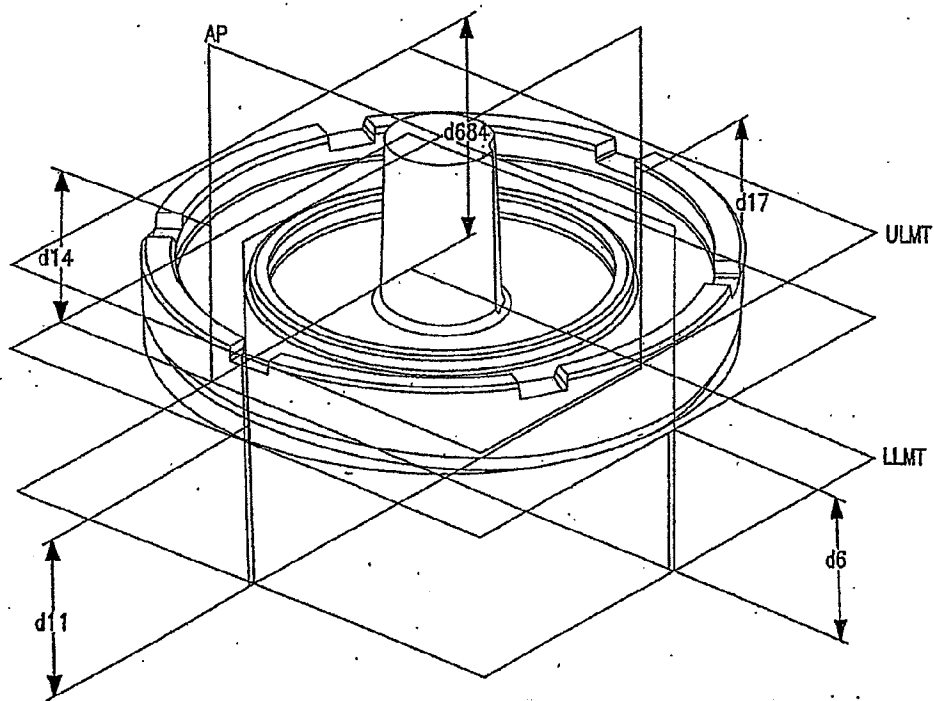
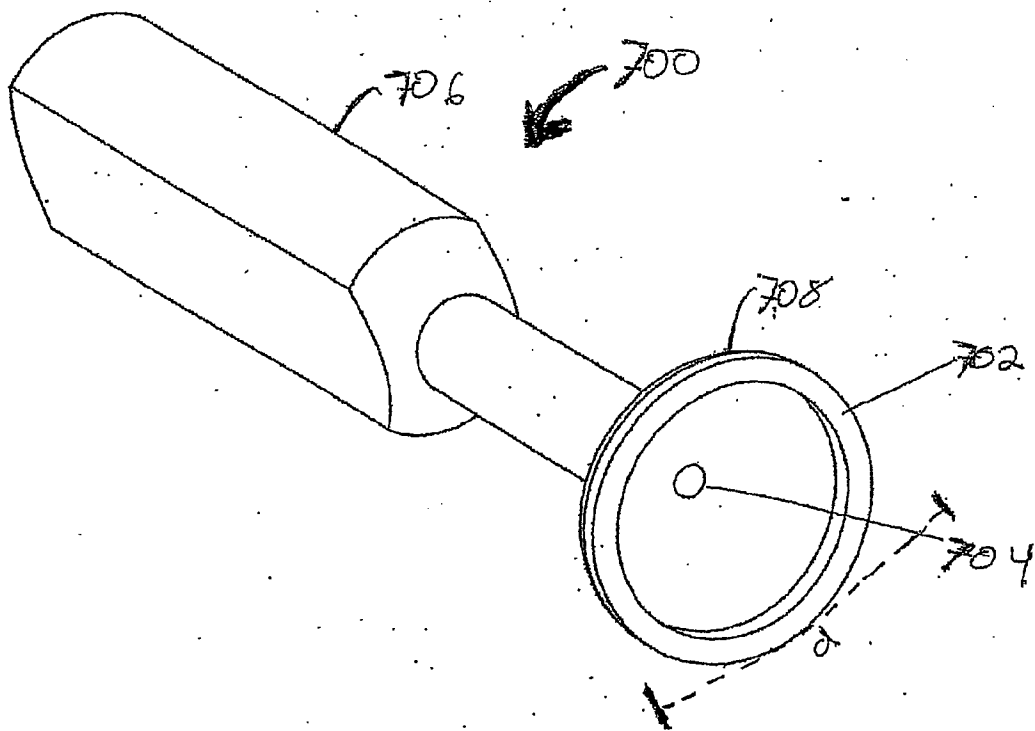

FIG. 26

Figure 27a



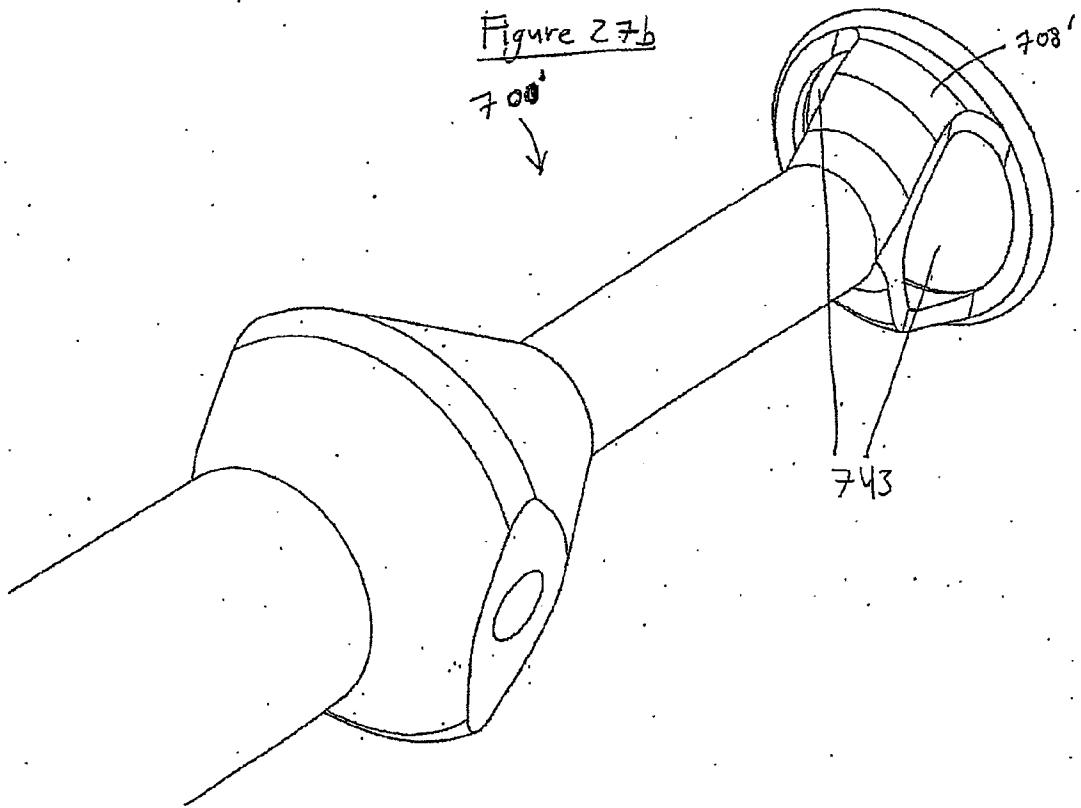
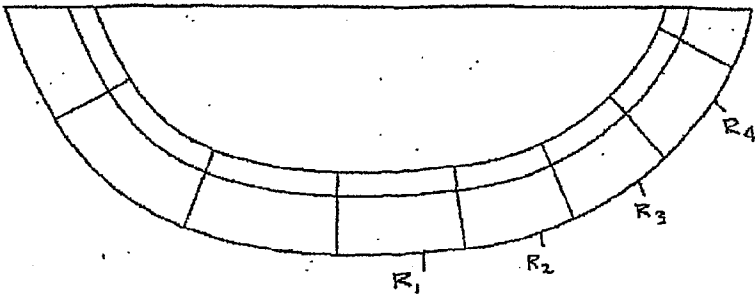

Figure 28a ↙ 710



710 ↘ Figure 28b

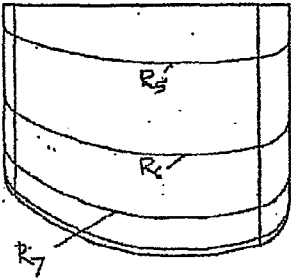

Figure 29

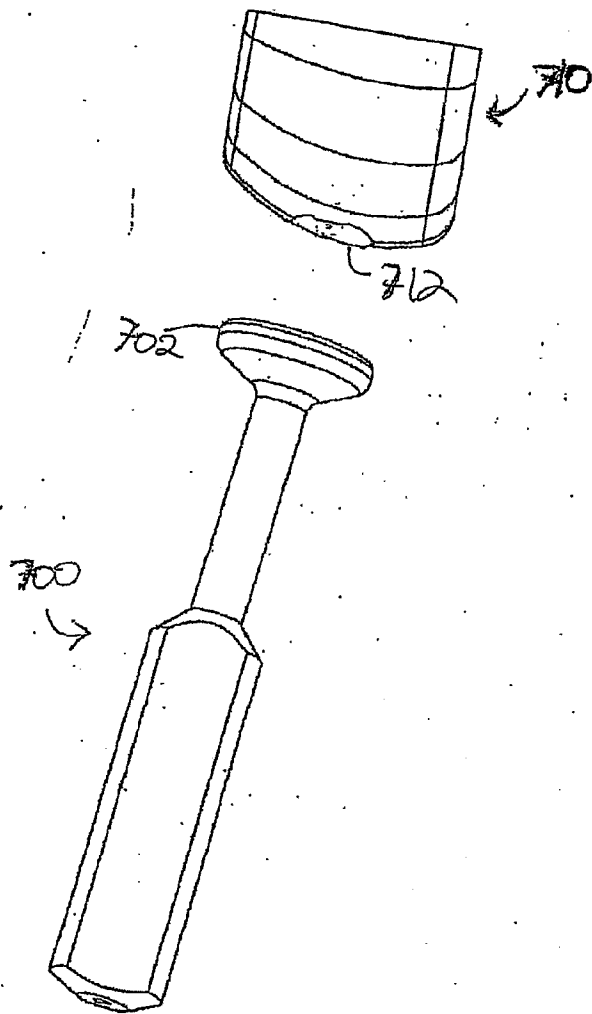

Figure 30

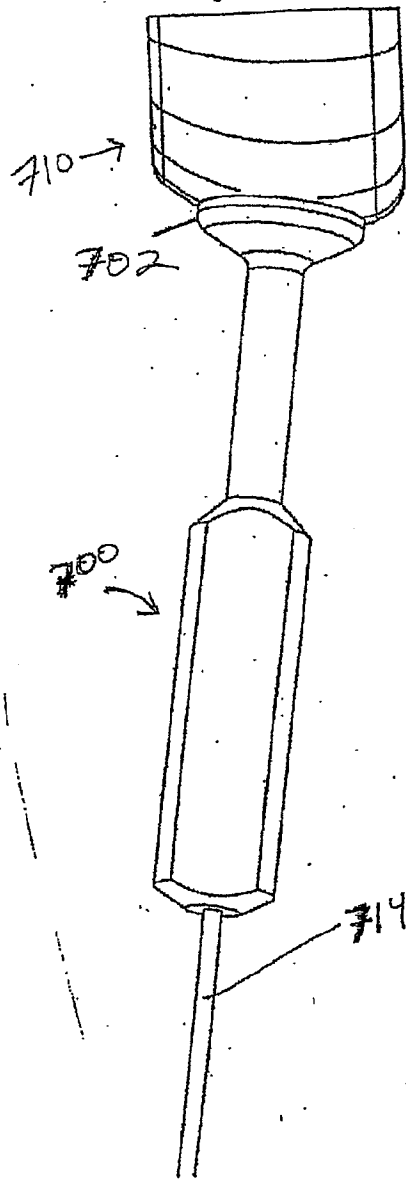
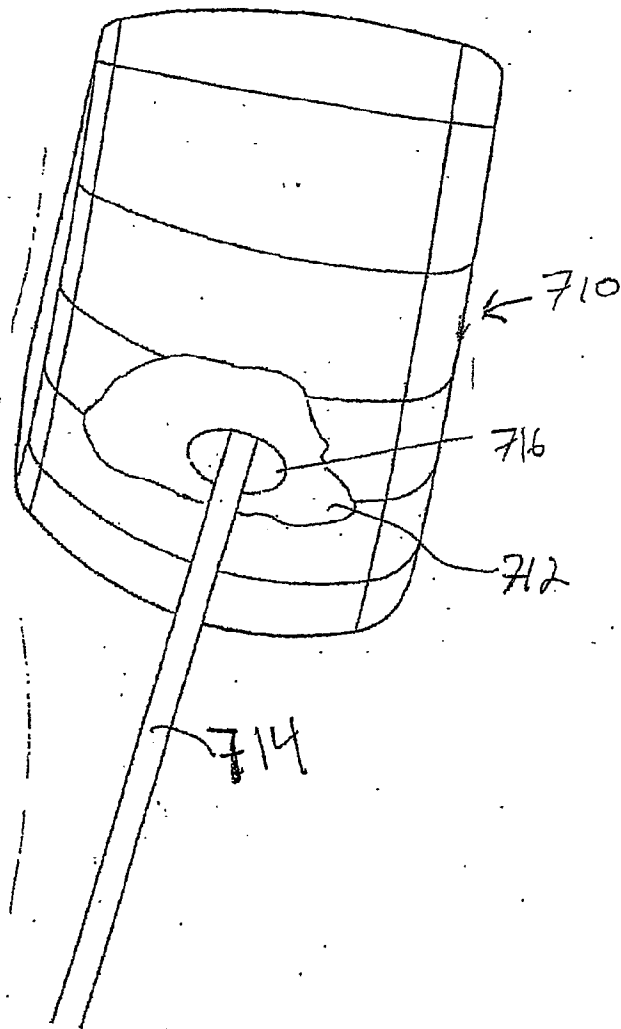

Figure 31



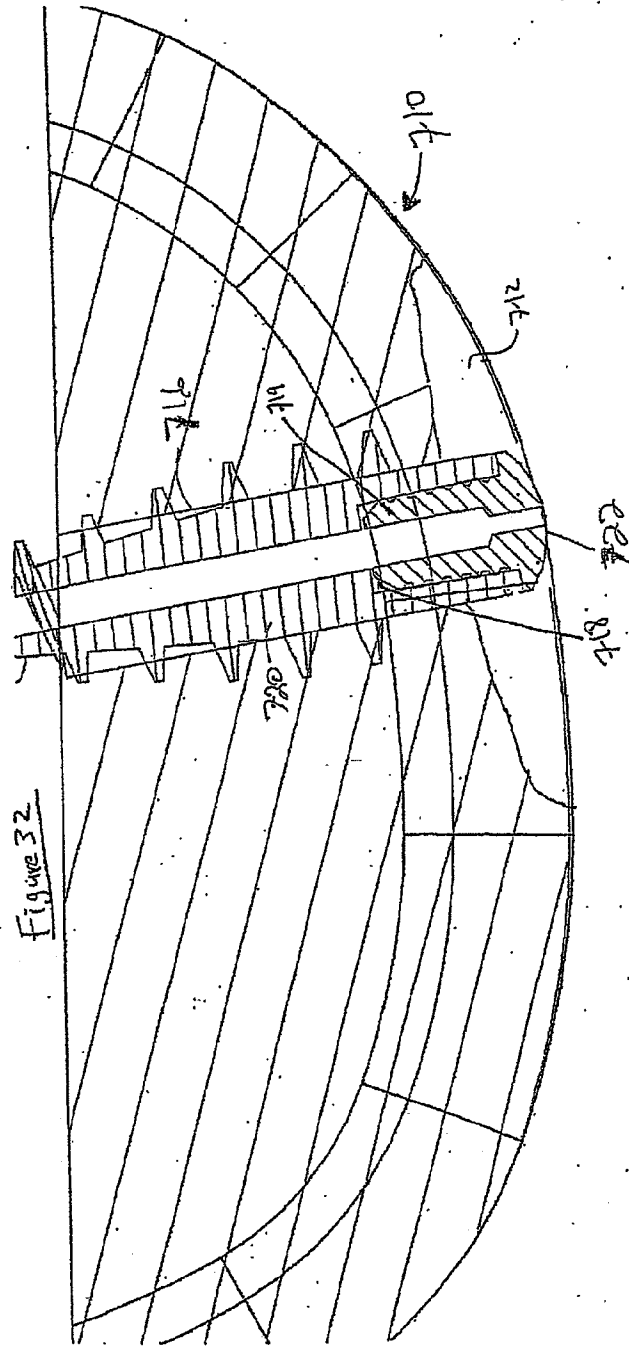

Figure 32

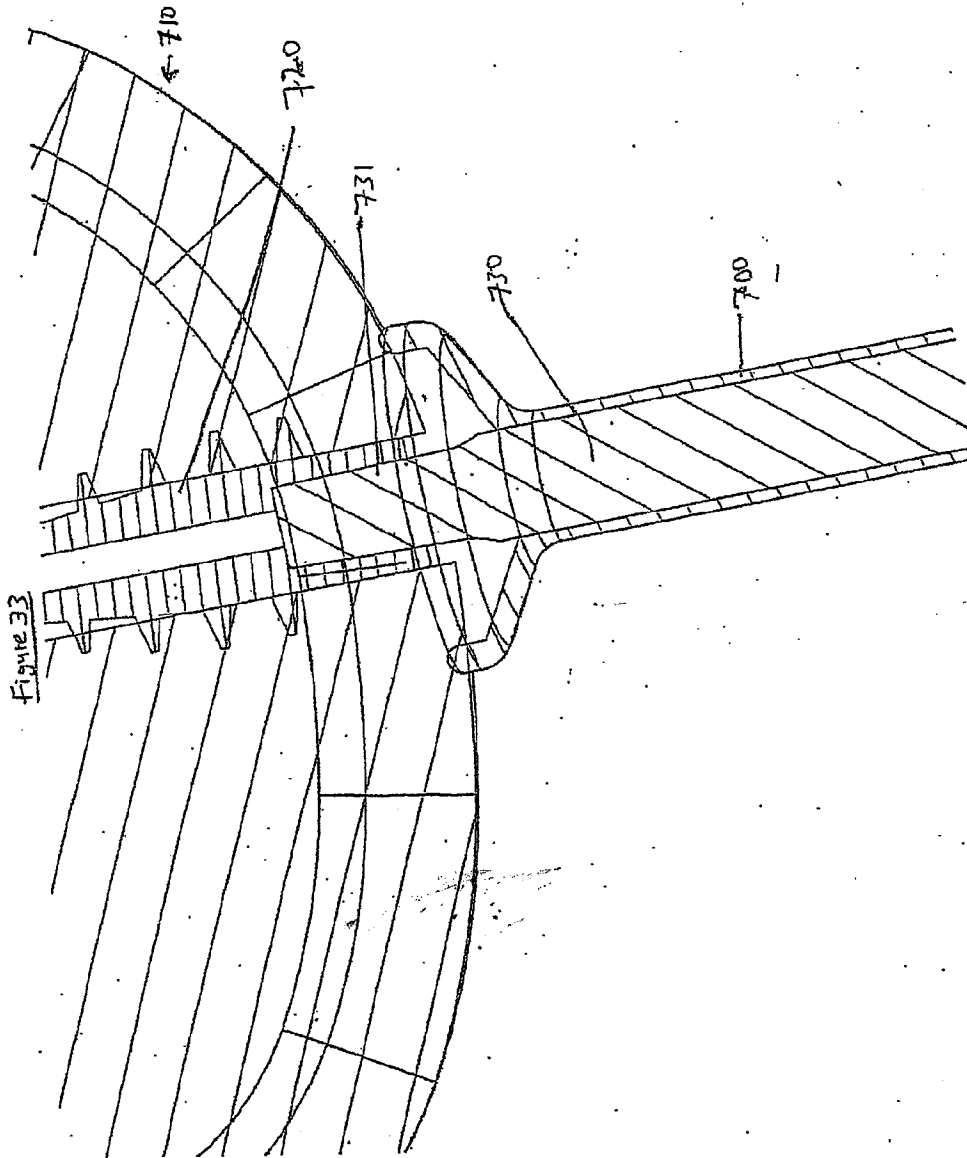

Figure 34

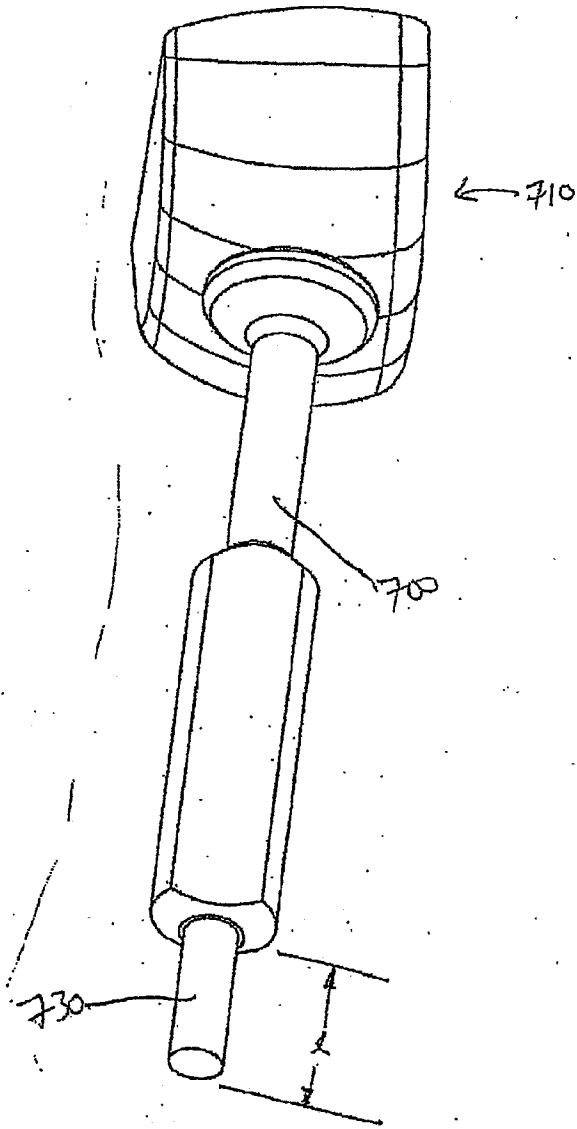

Figure 35

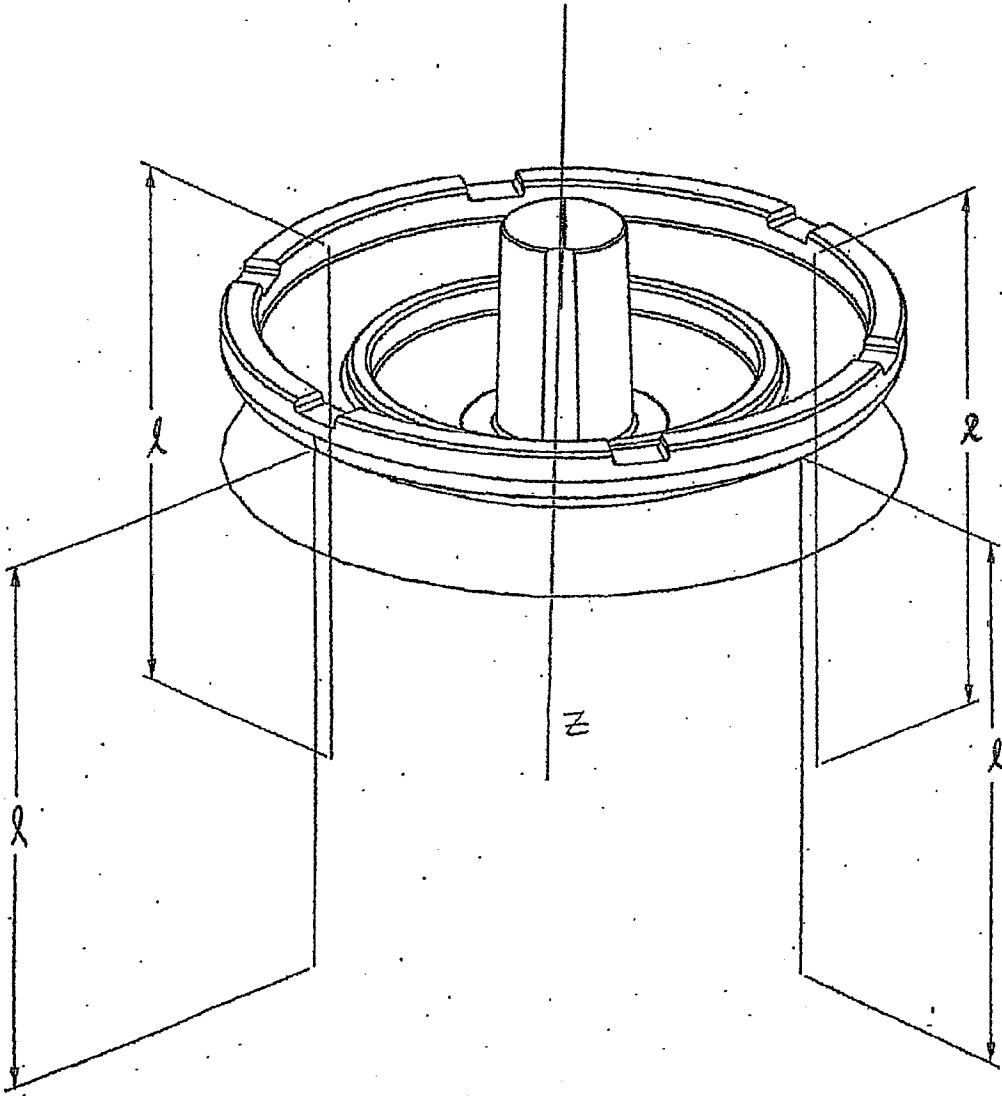

Figure 36

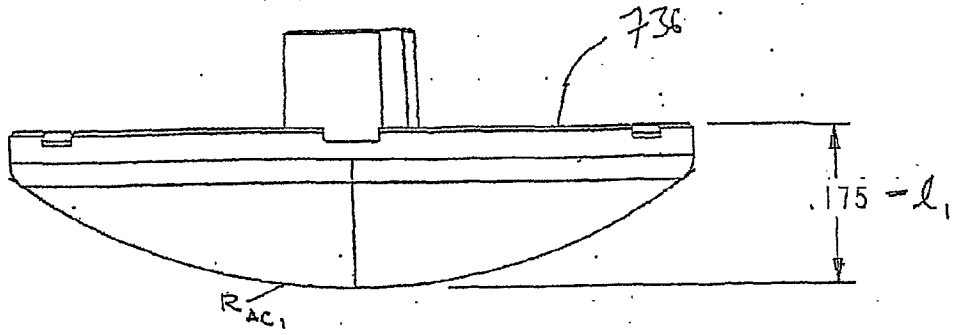

Figure 37

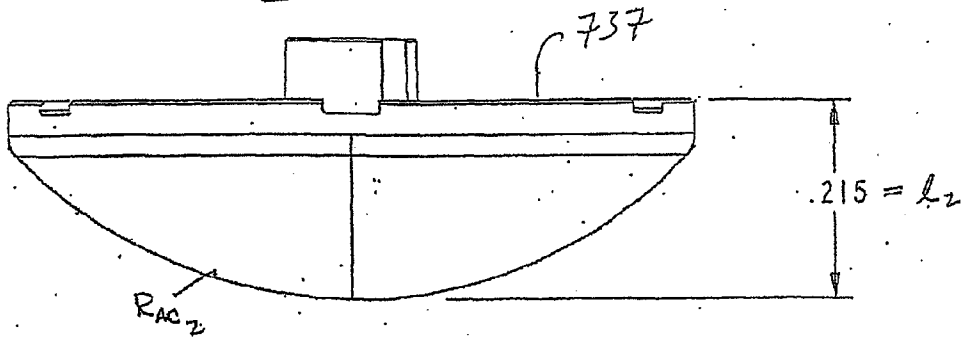
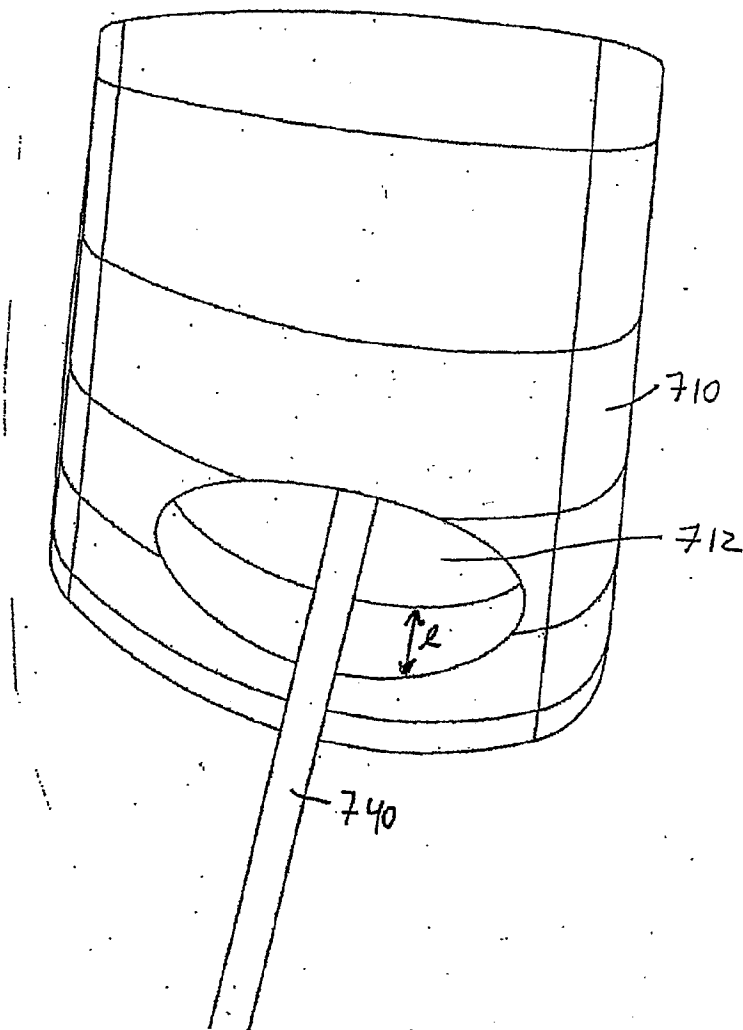
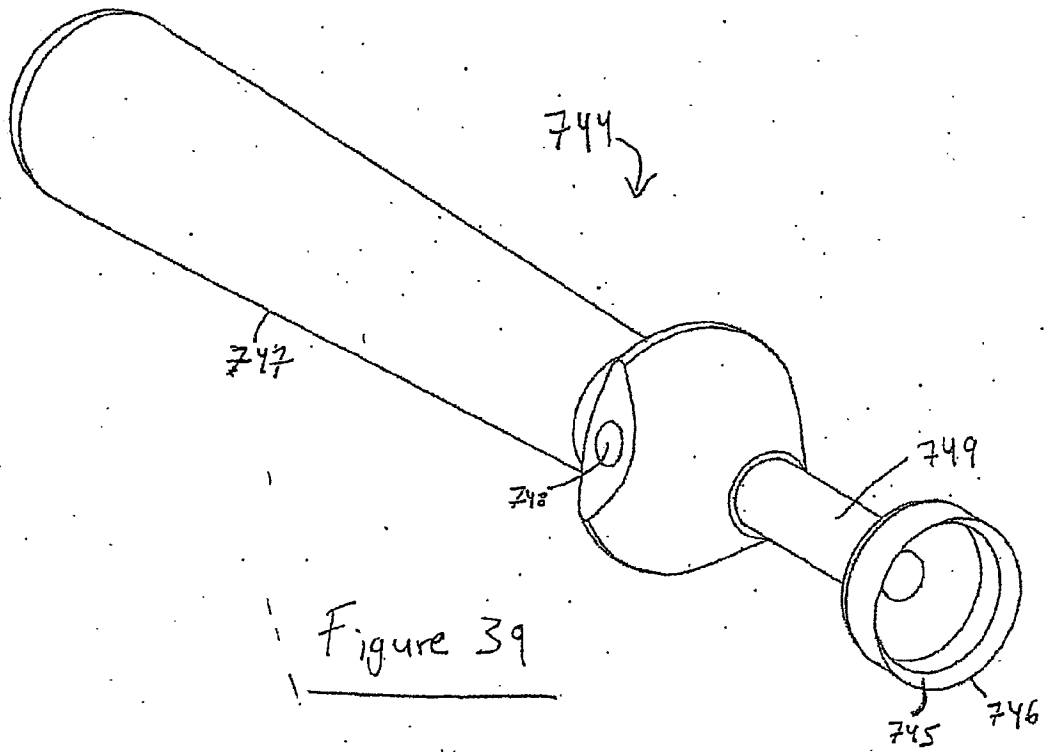

Figure 38





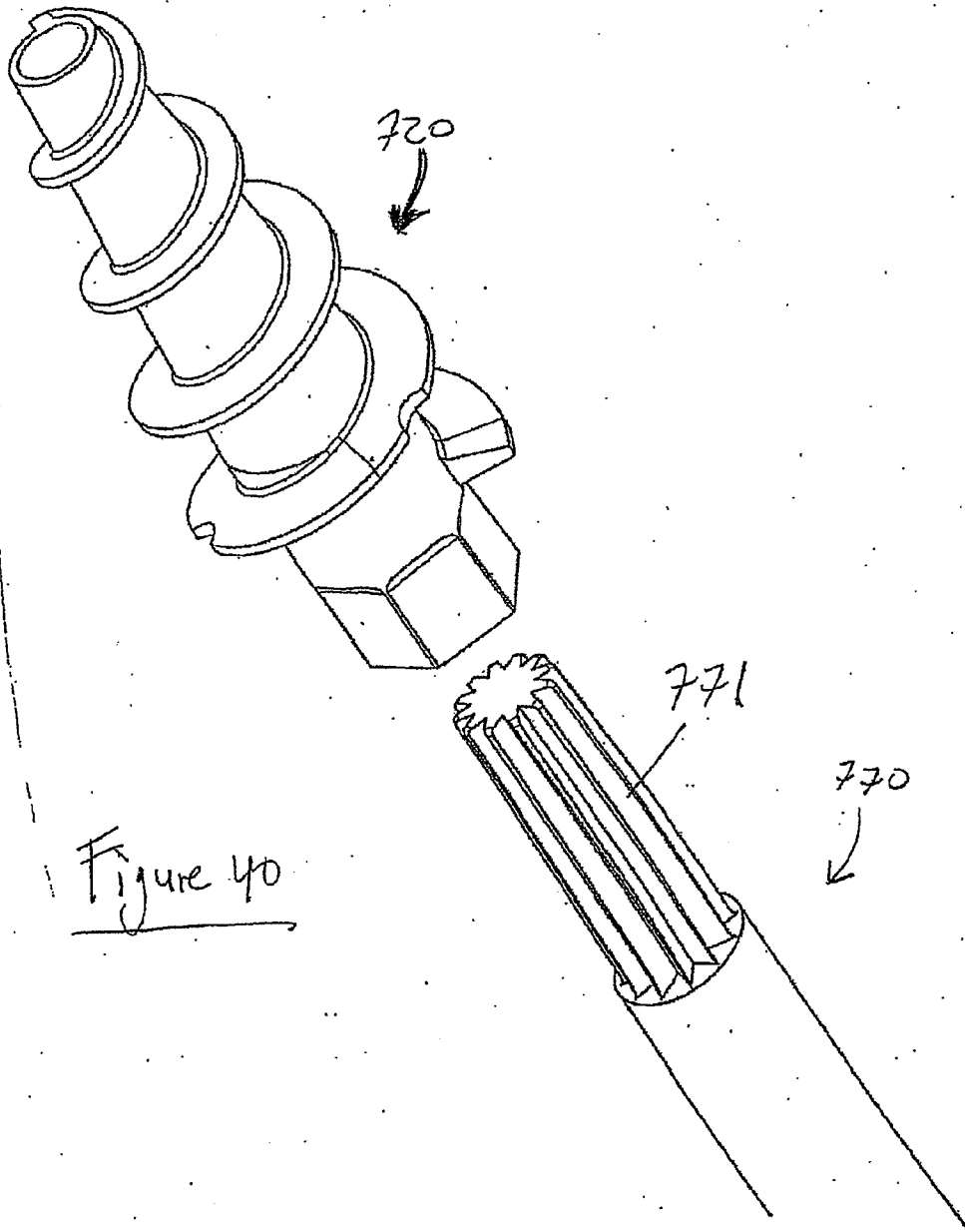

Figure 40

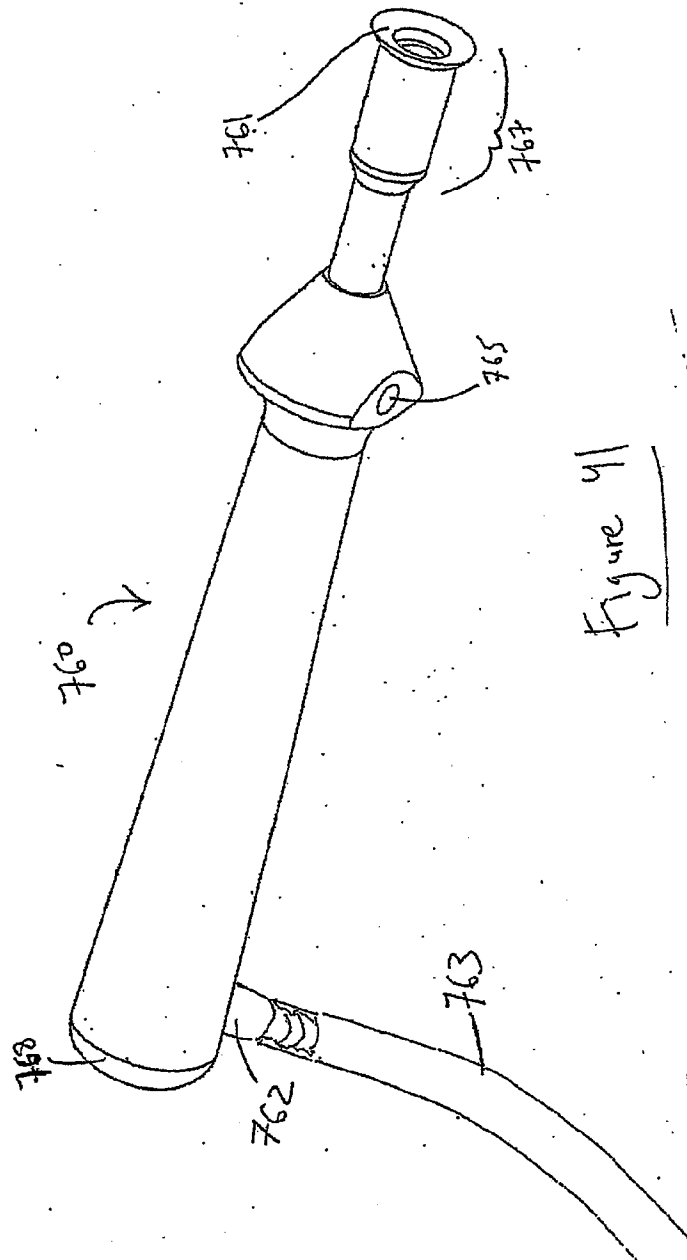

Figure 91

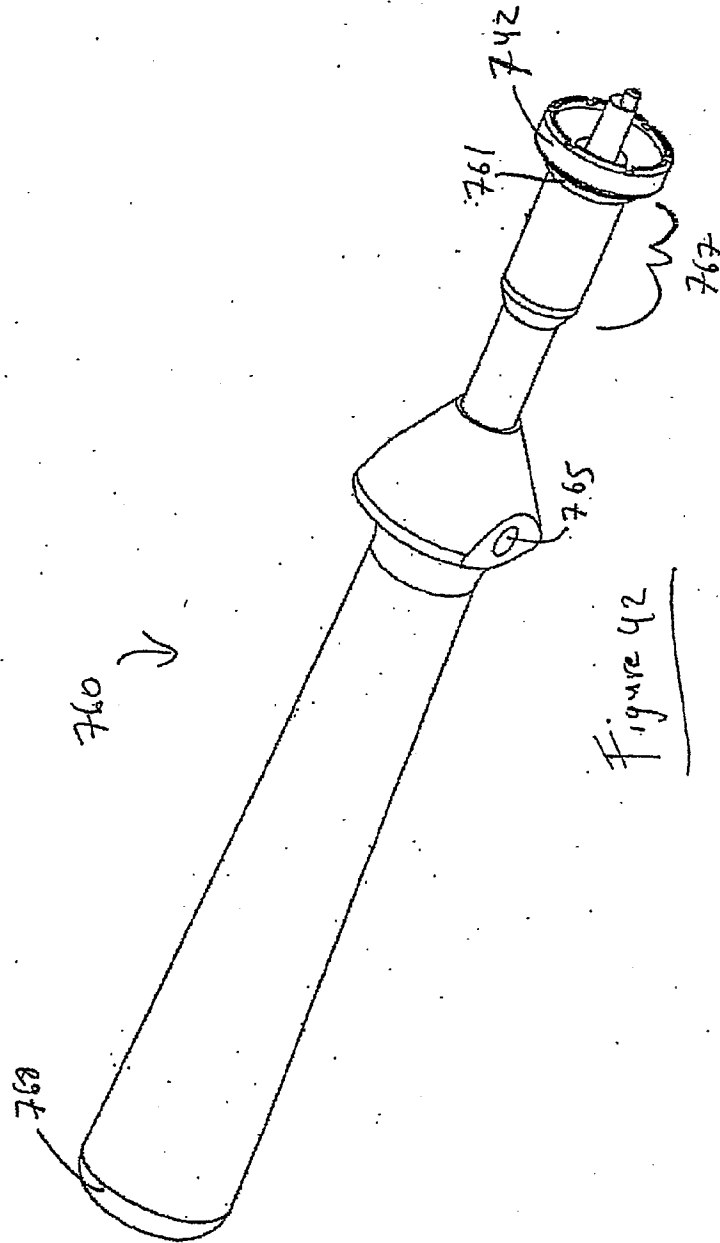
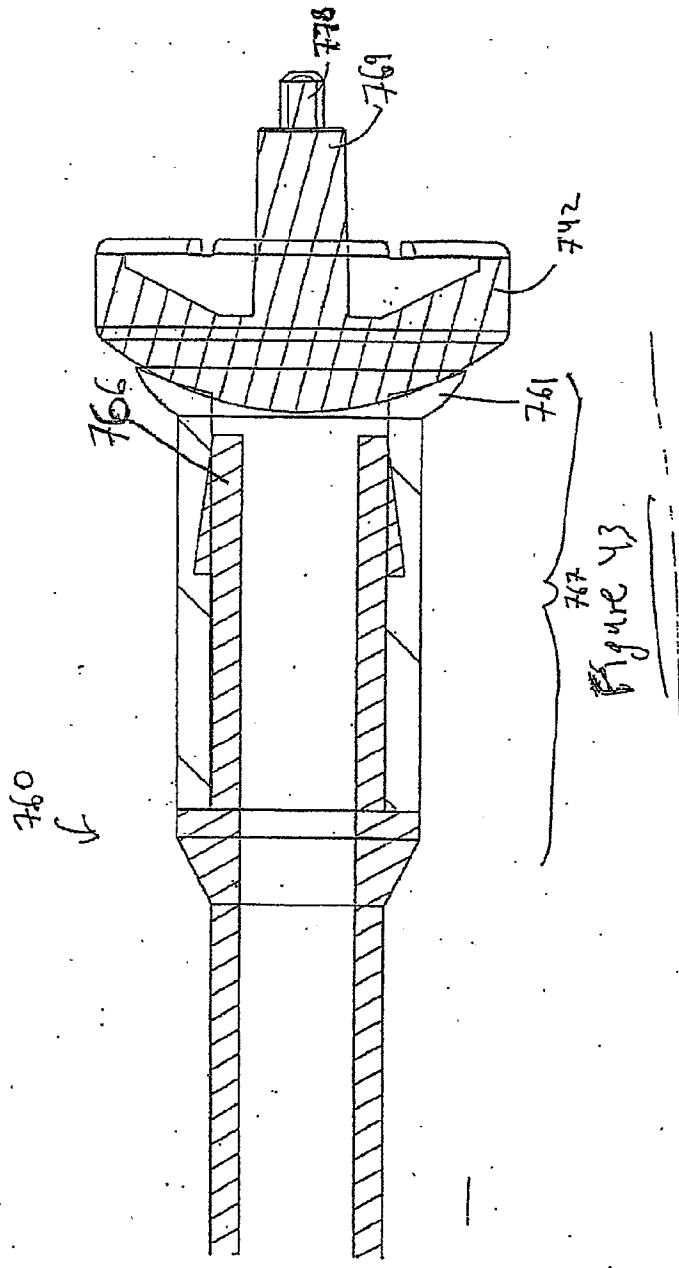

Figure 42



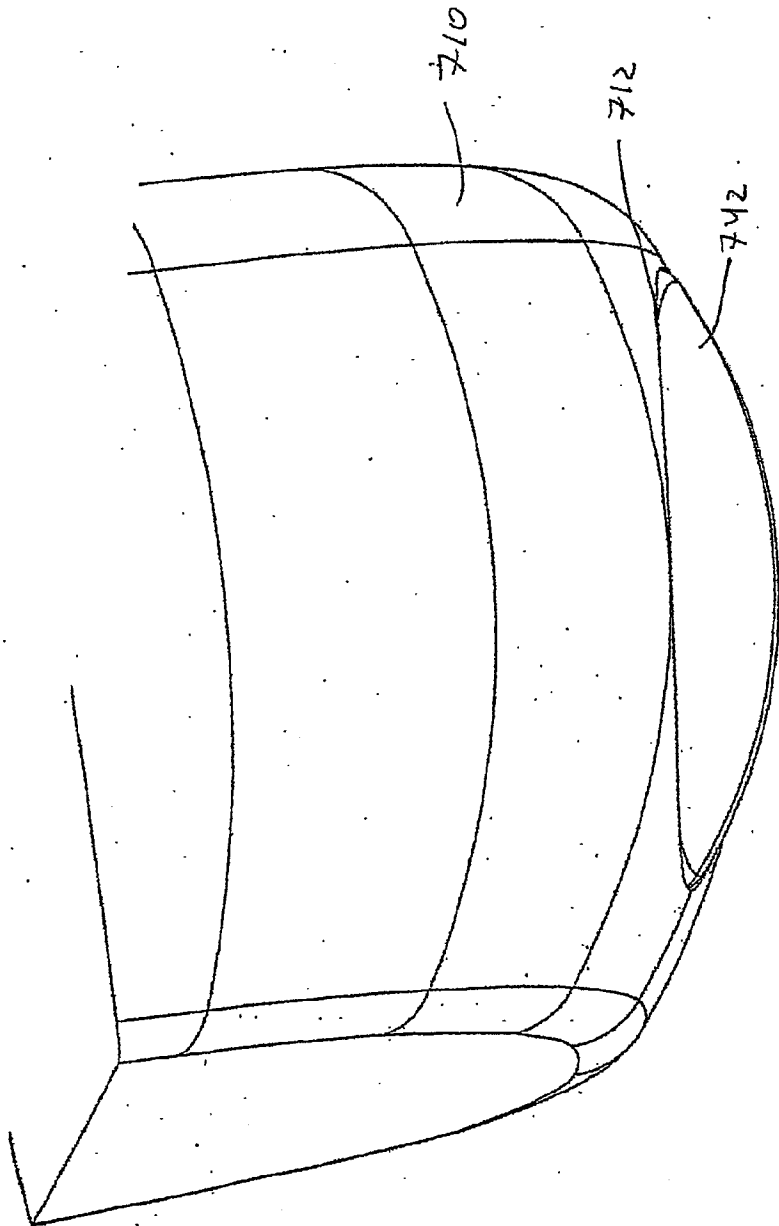

Figure 44

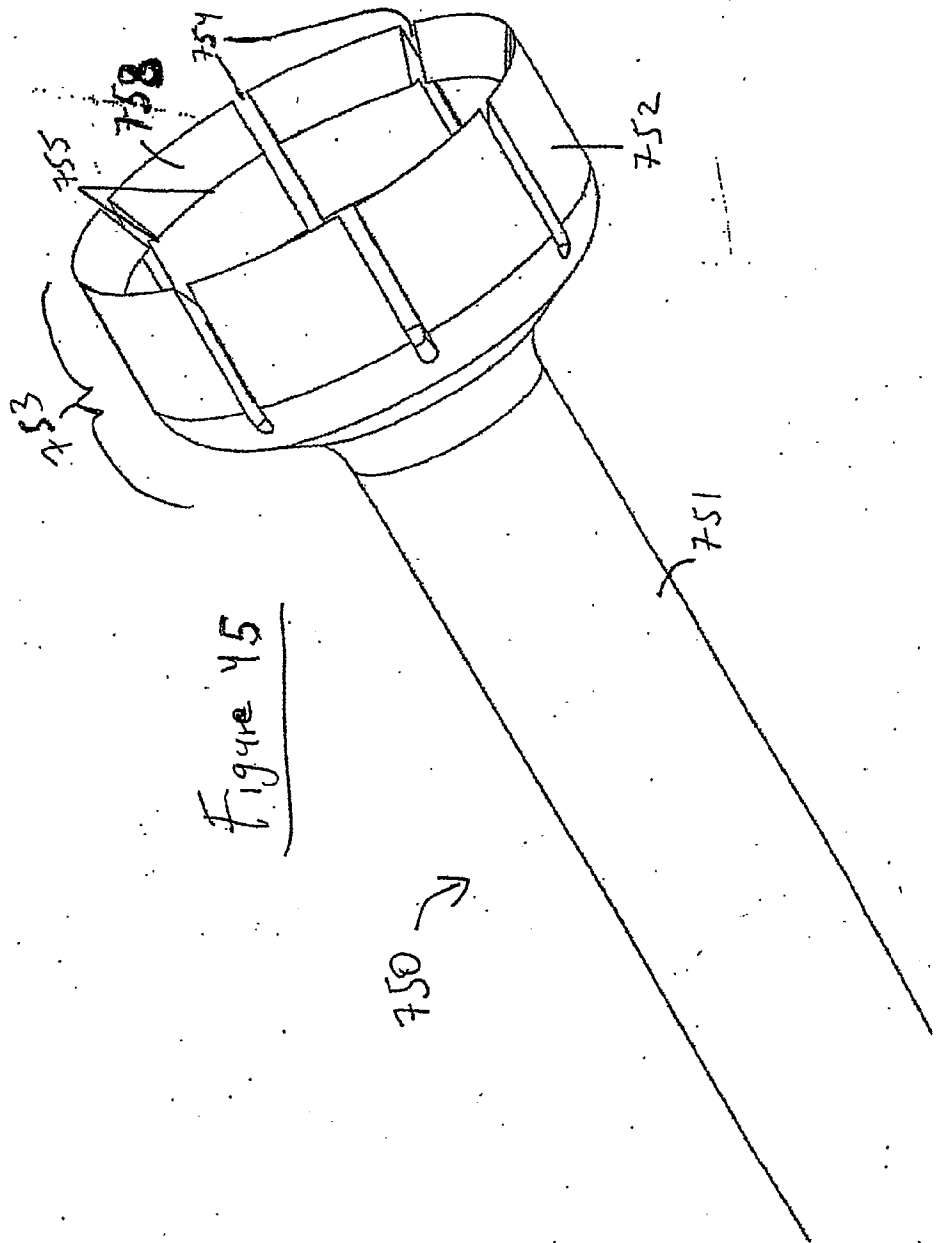

Figure 15

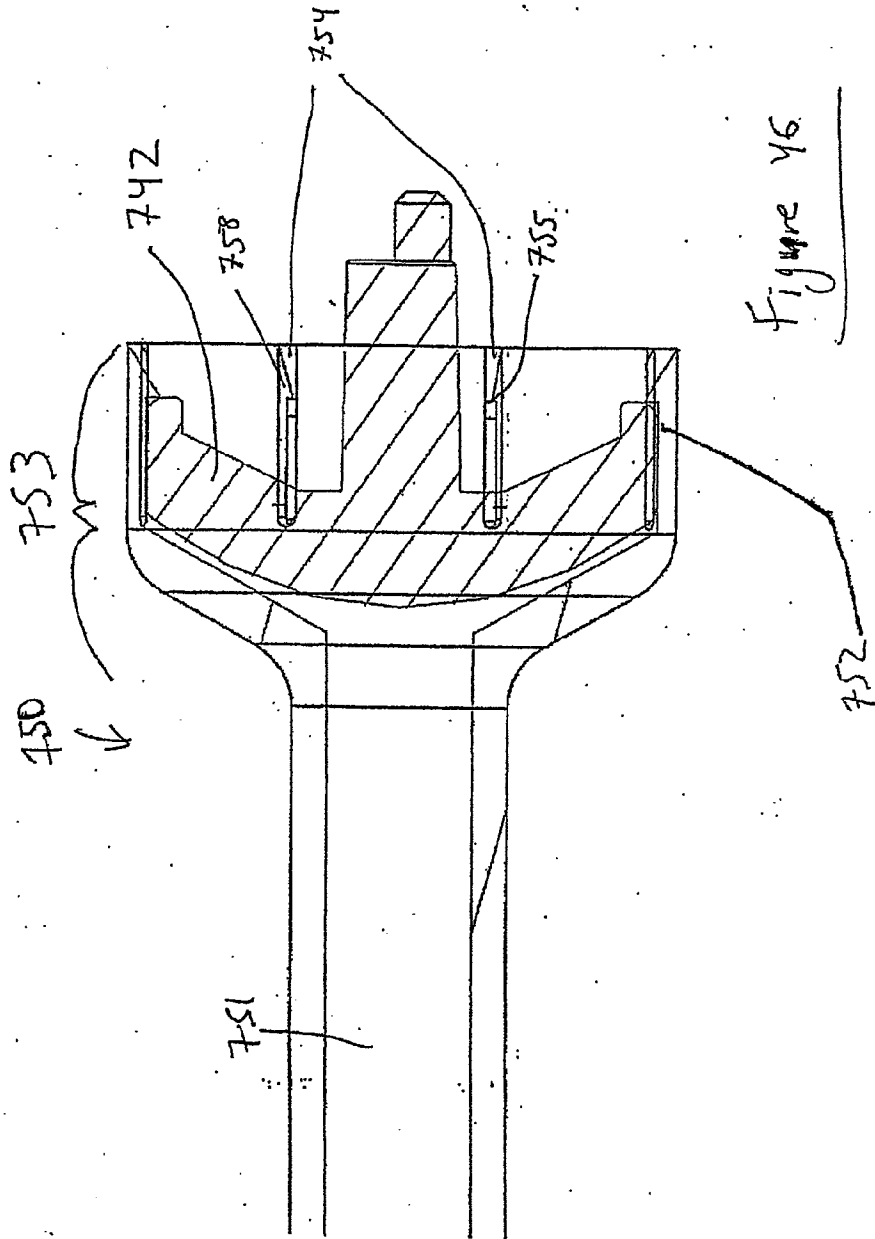

Figure 46

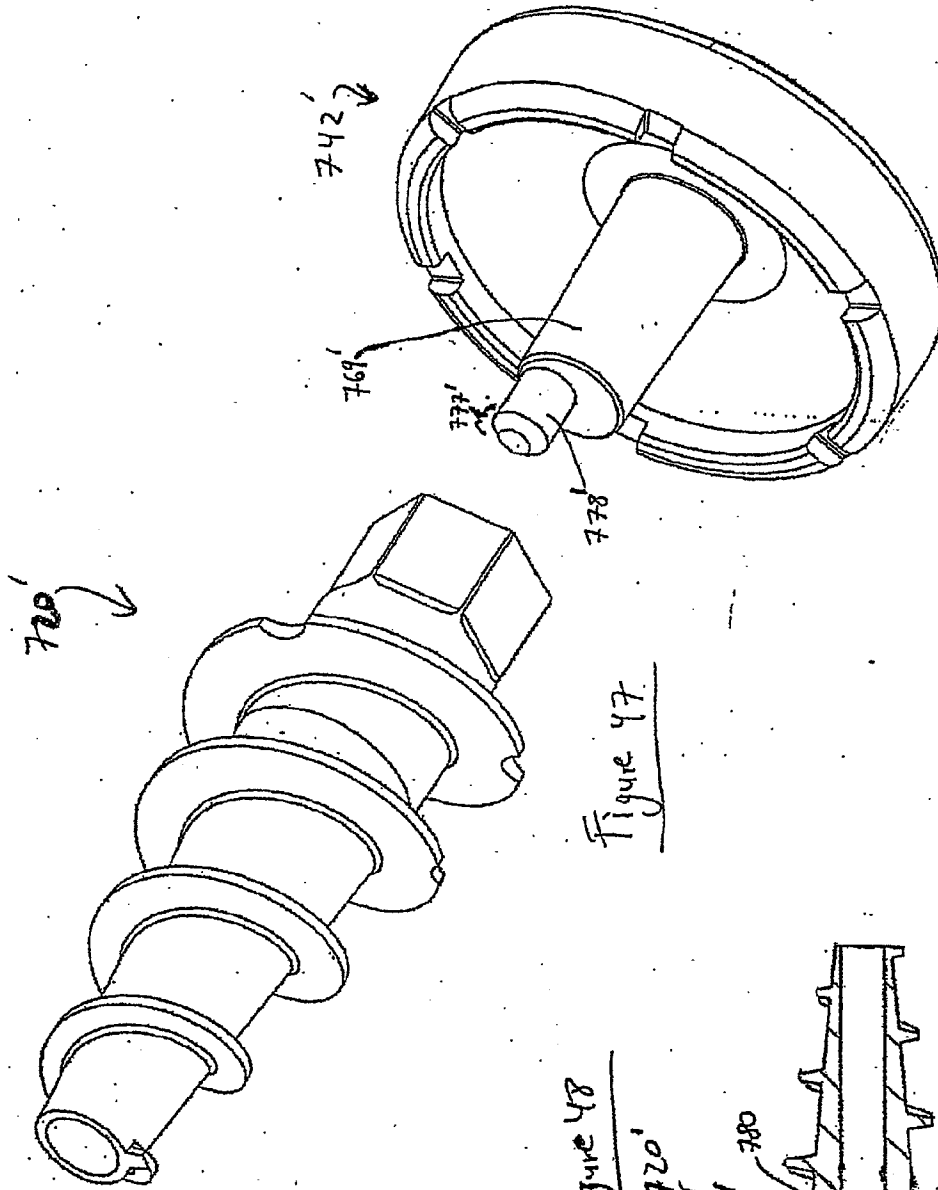

Figure 47

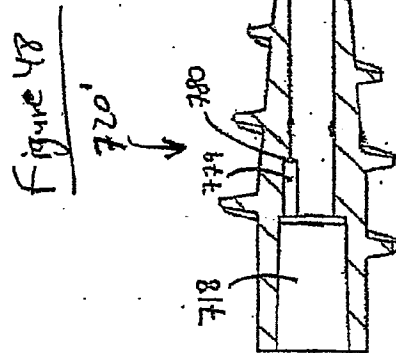

Figure 48

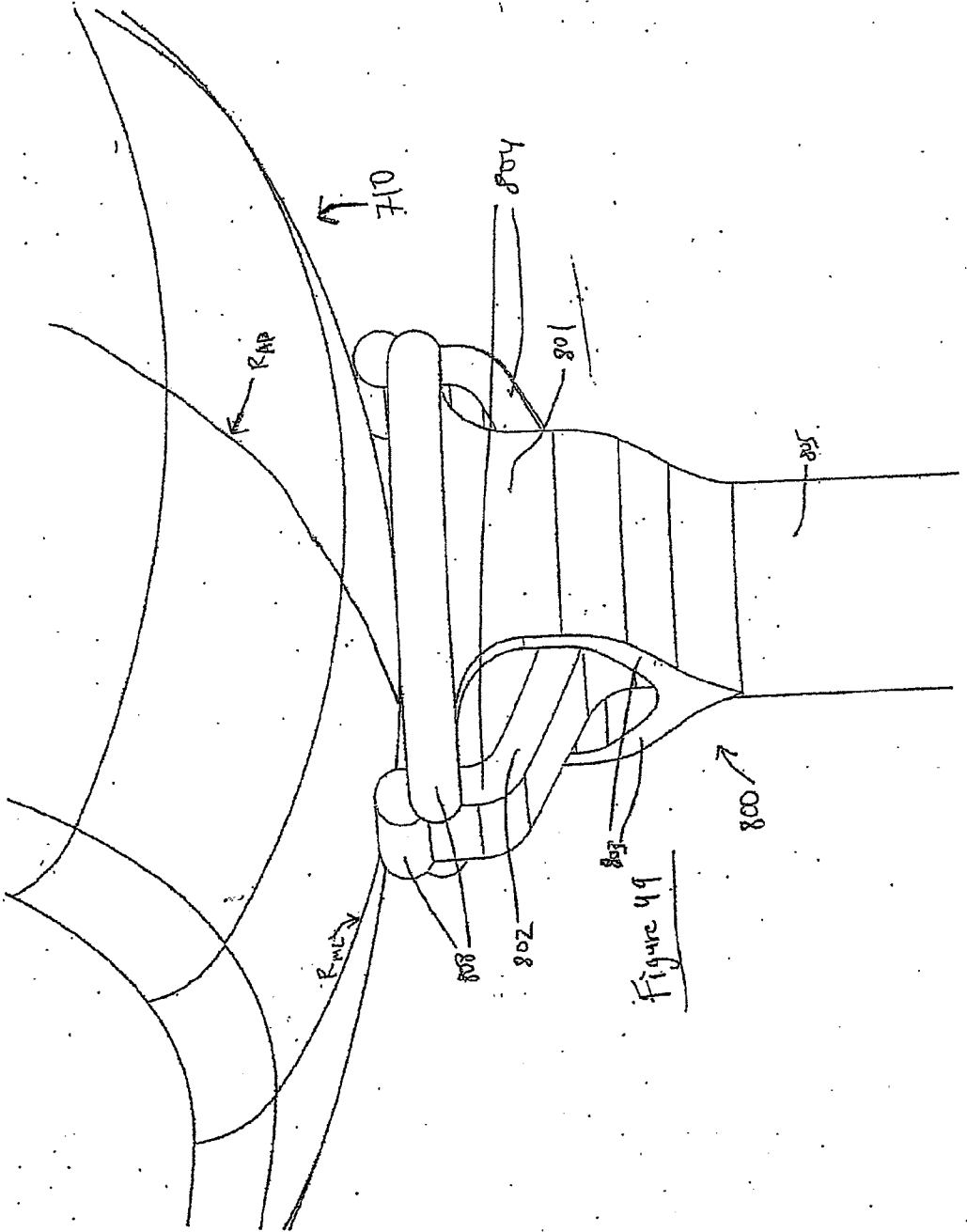

Figure 49

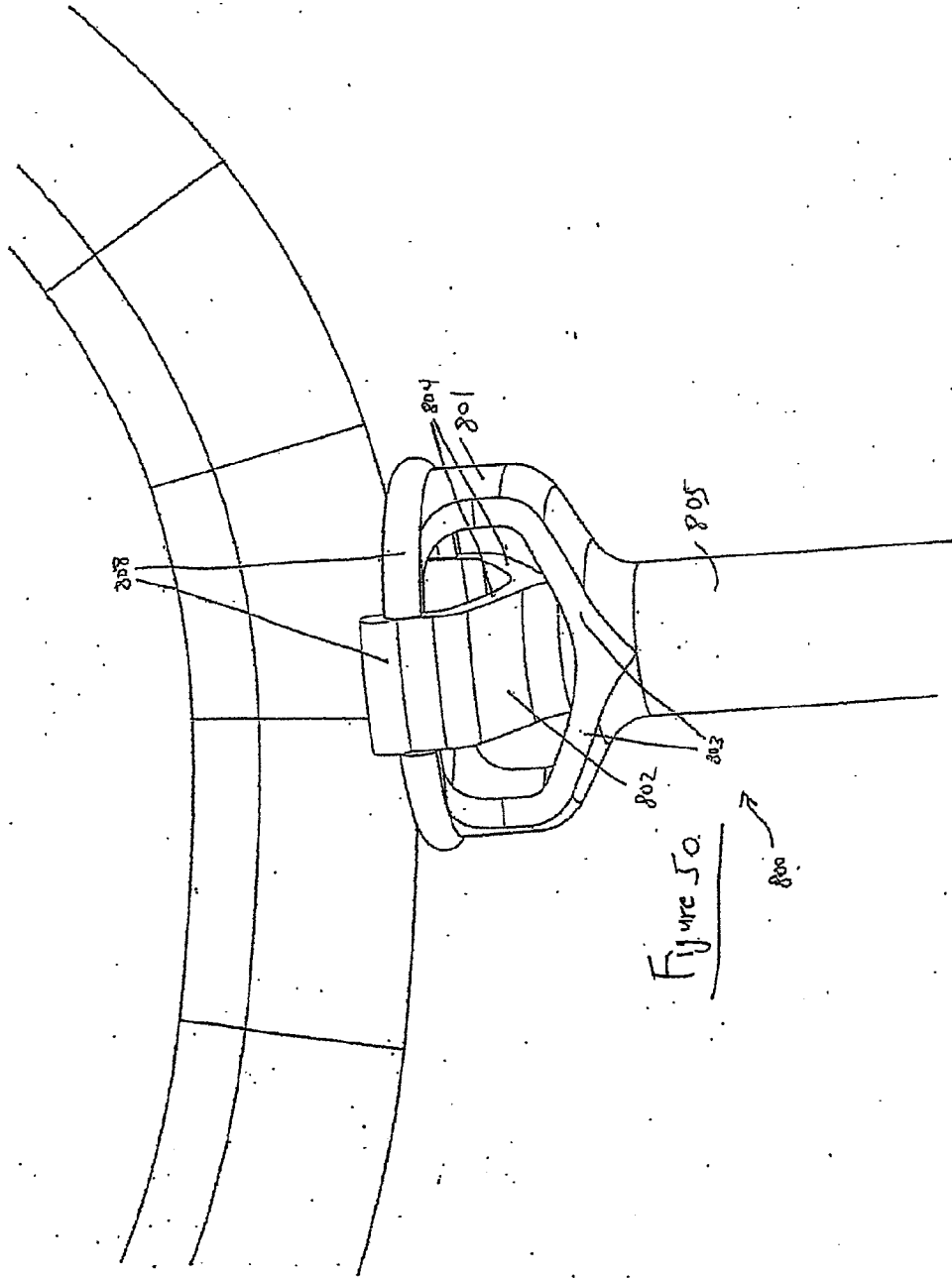
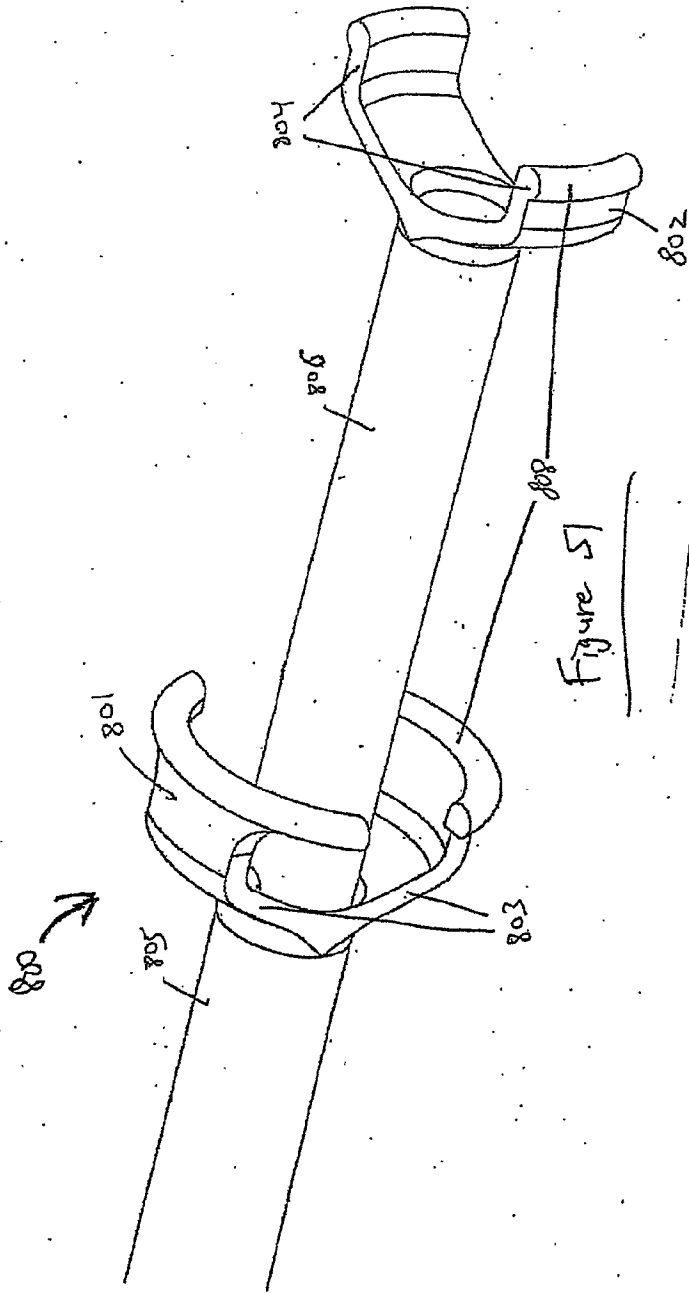

Figure 50.



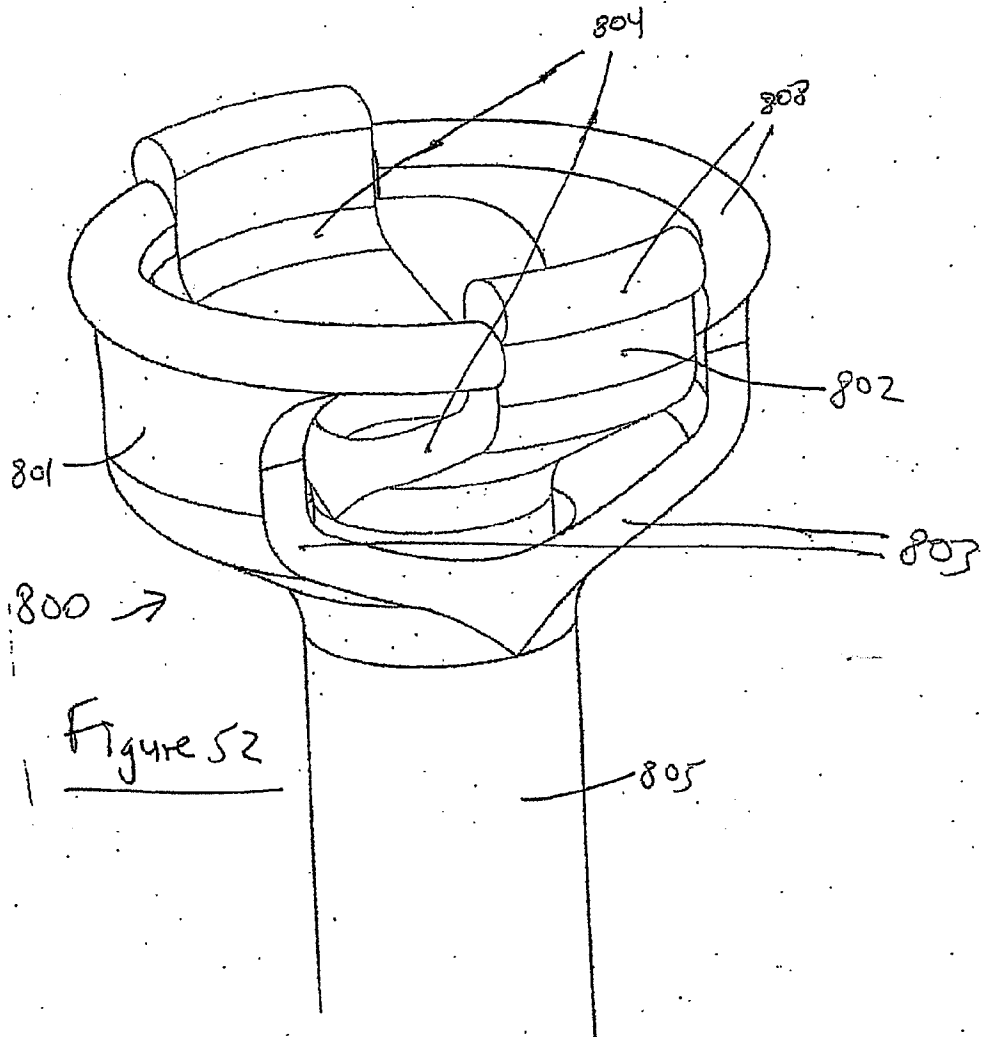

Figure 52

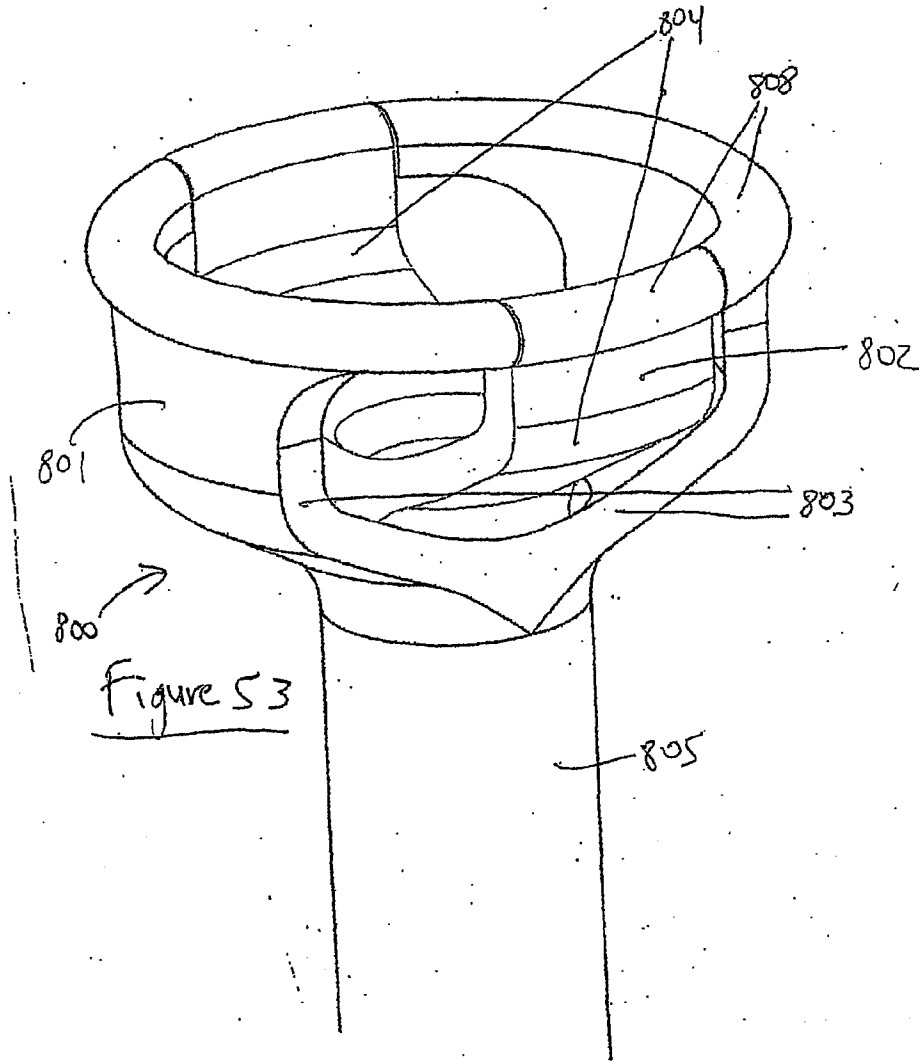

Figure 53

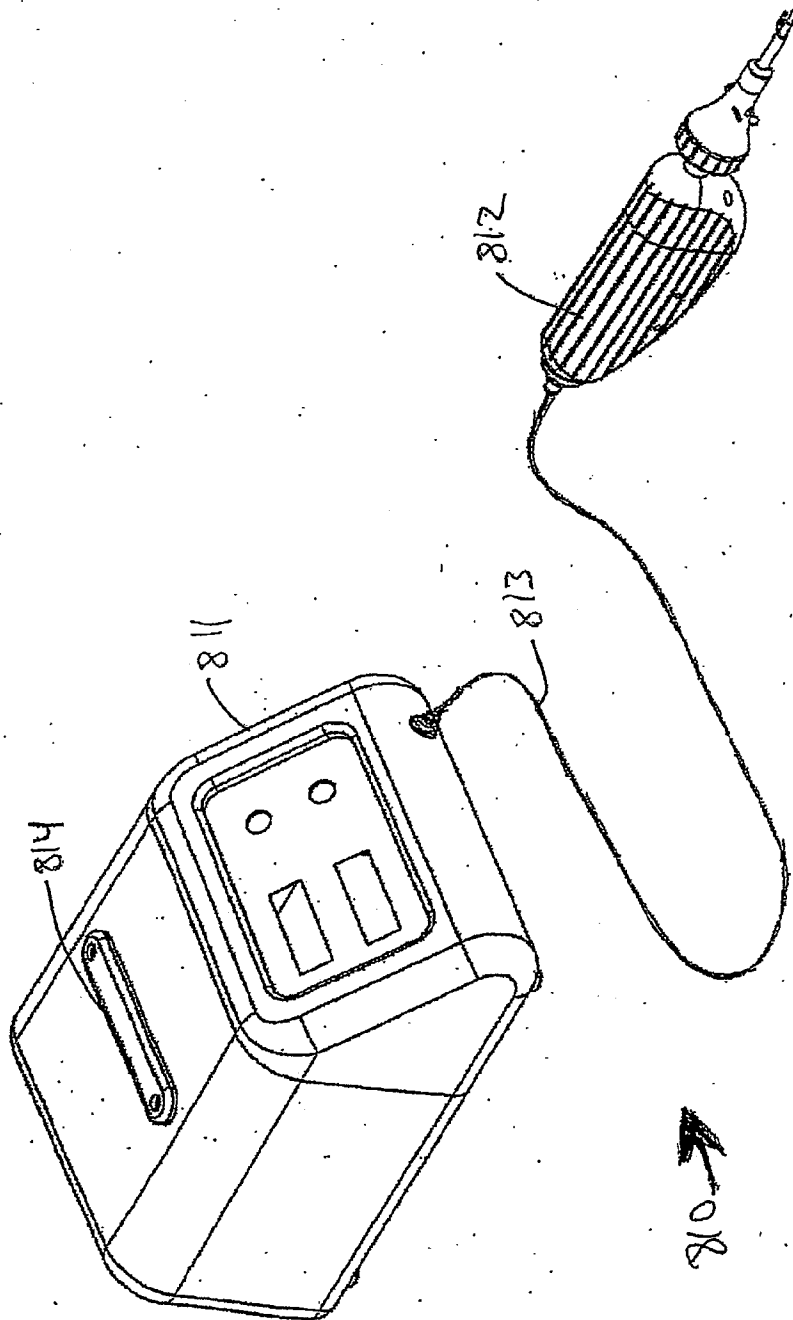
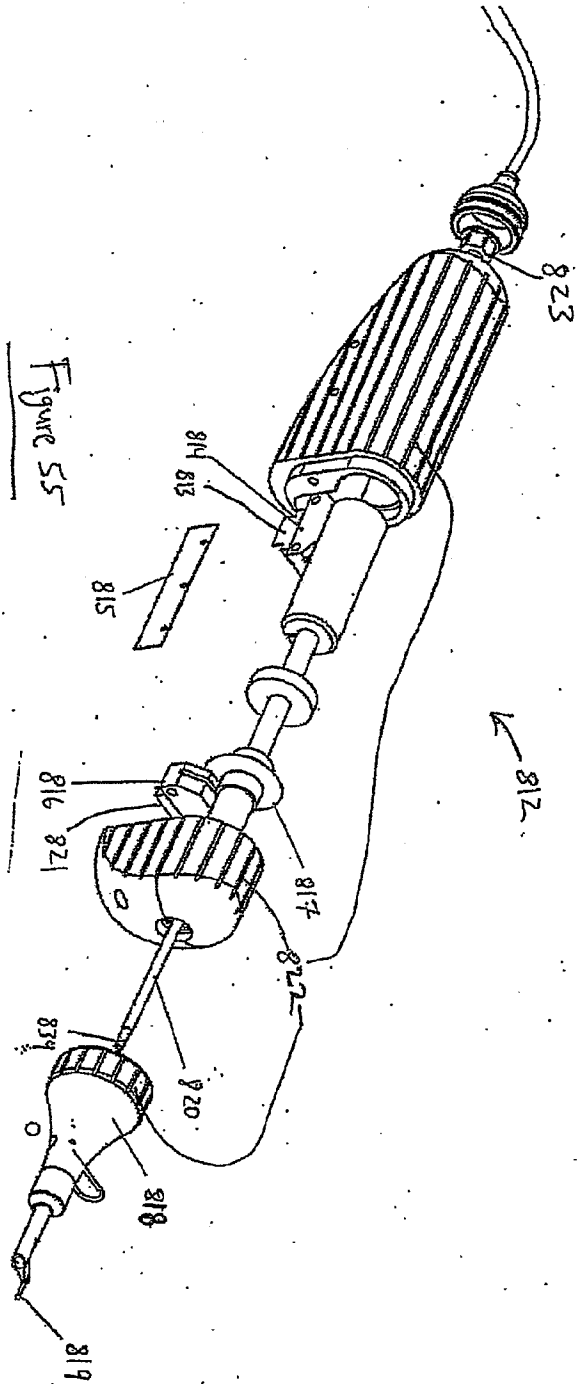

Figure 54



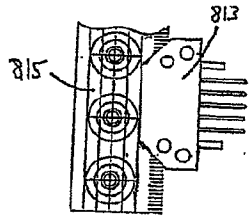

Figure 55a

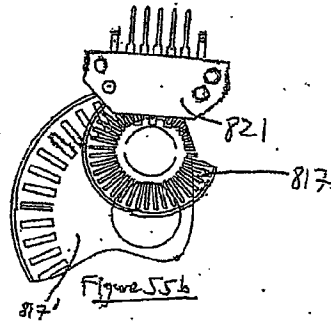

Figure 55b

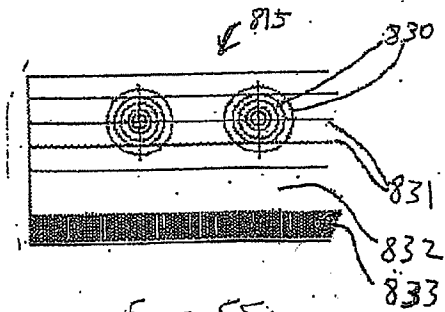

Figure 55c

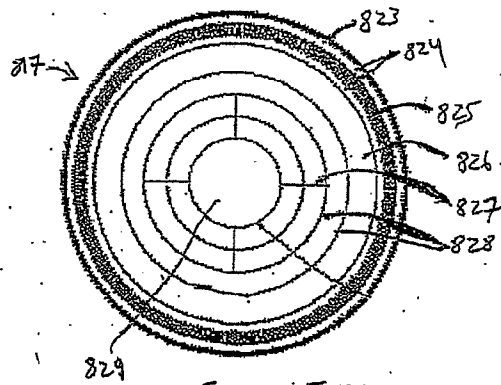

Figure 55d

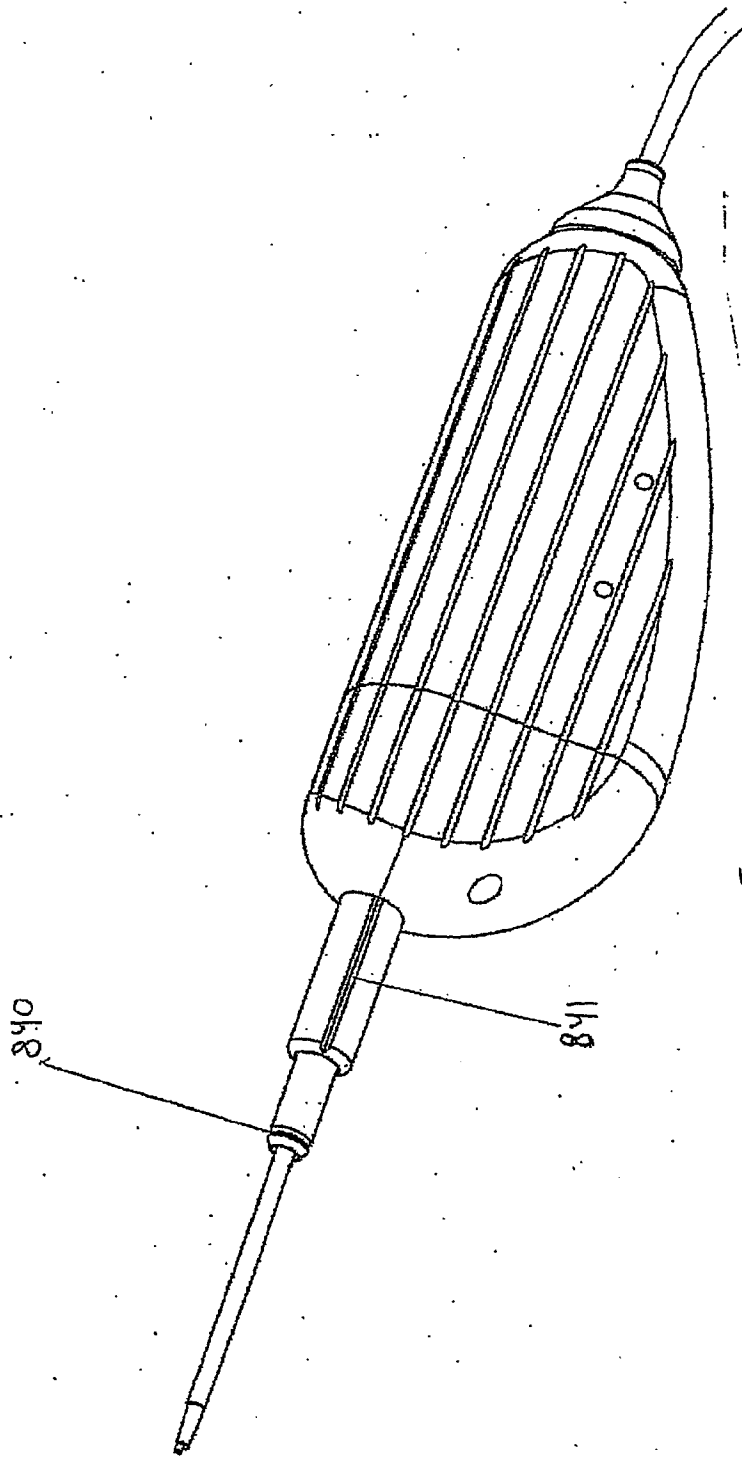

Figure 56a

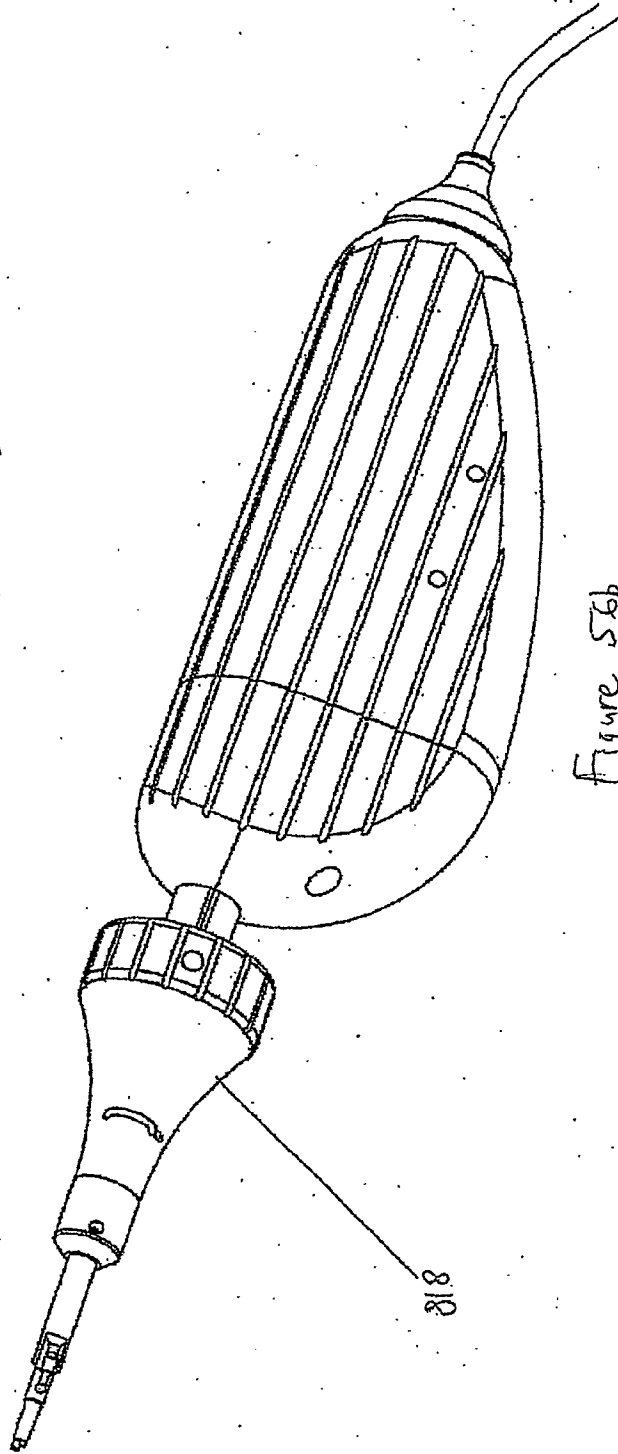

Figure 56b

818

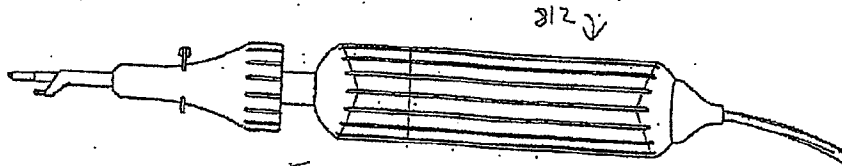

Figure 57

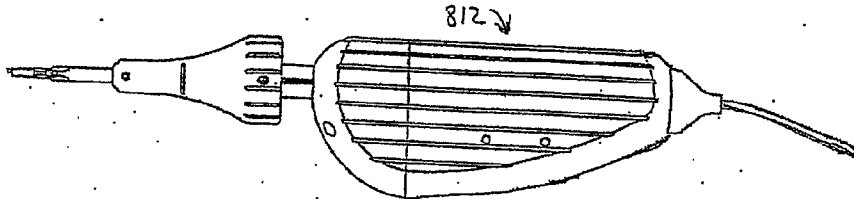

Figure 58

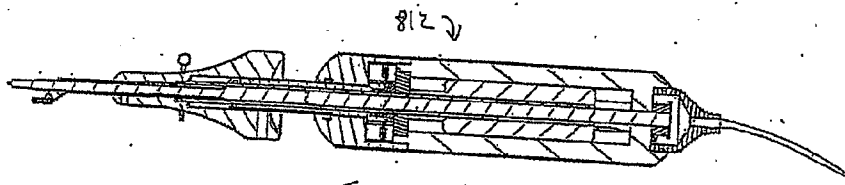

Figure 59

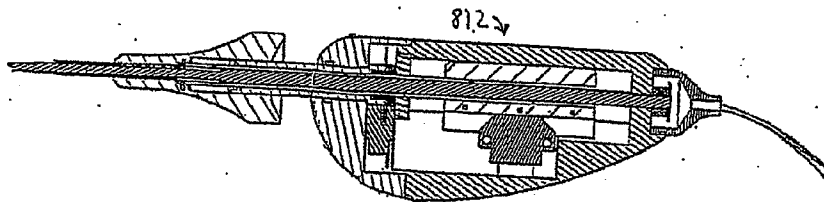
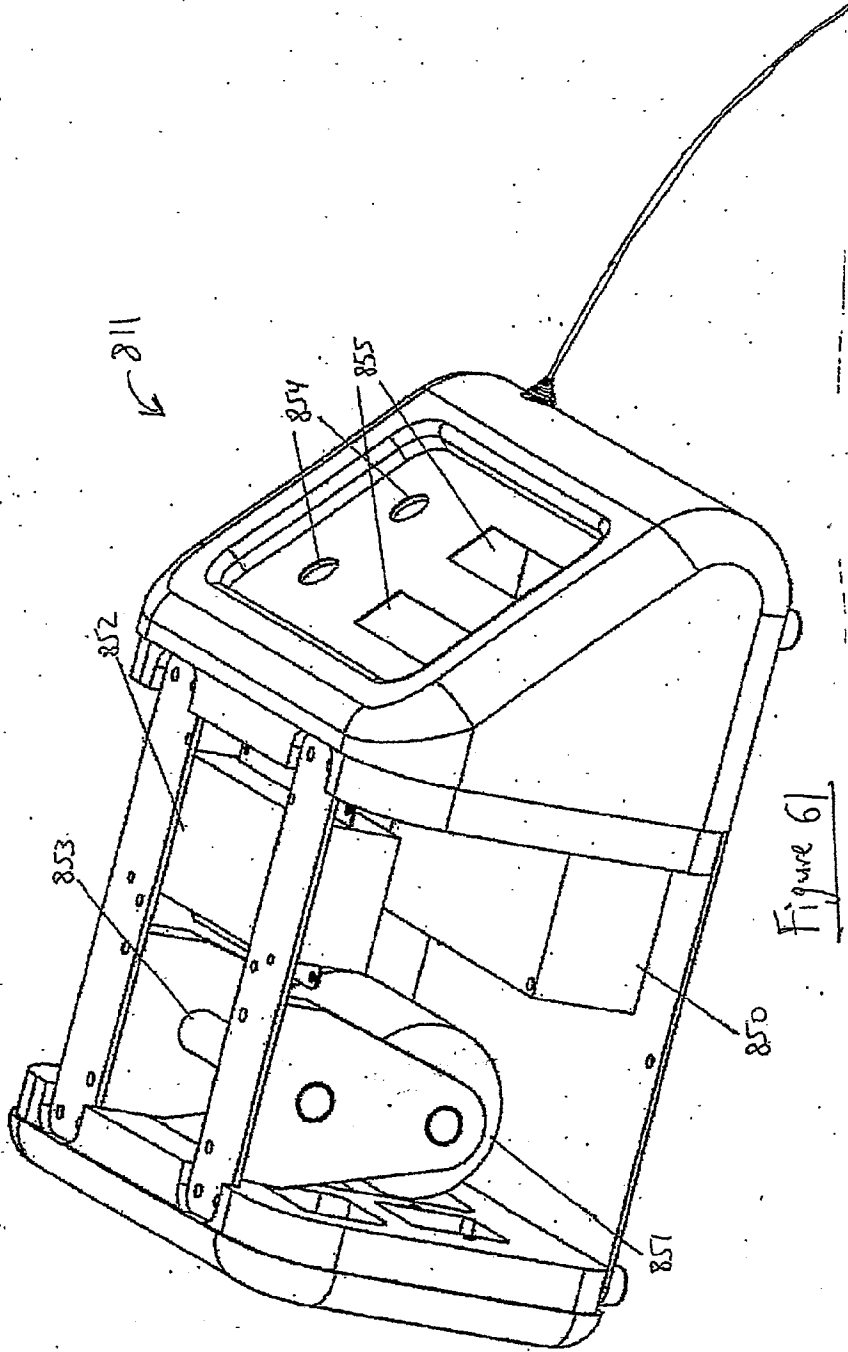

Figure 60



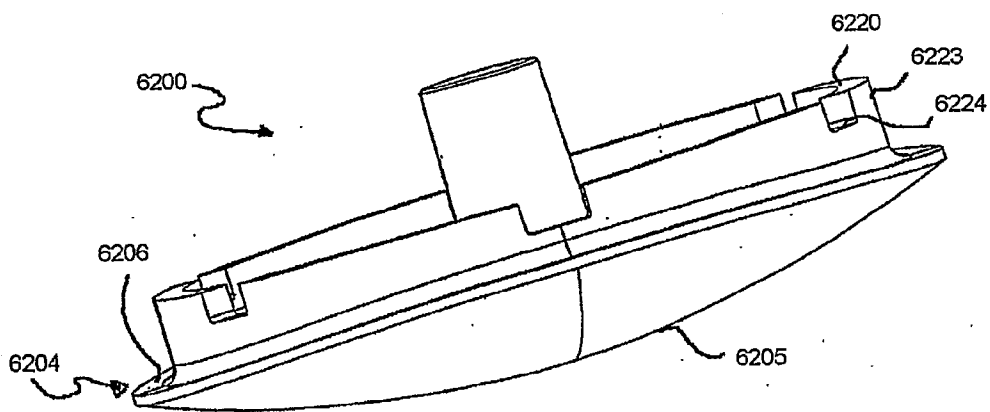

FIG. 62C

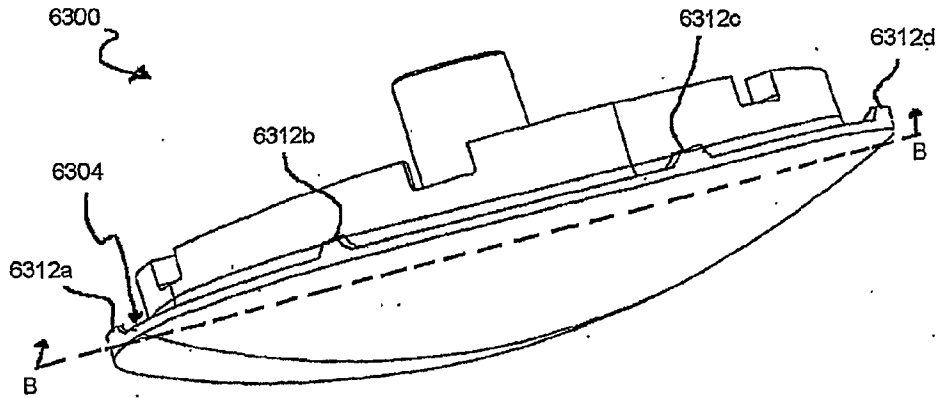

FIG. 63A

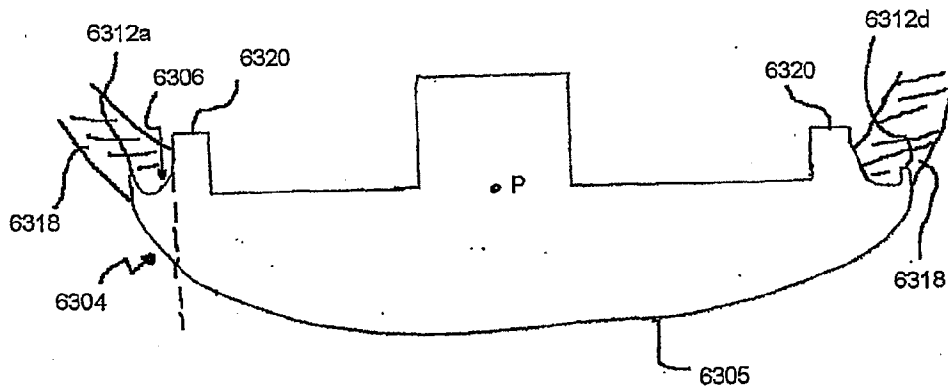

FIG. 63B

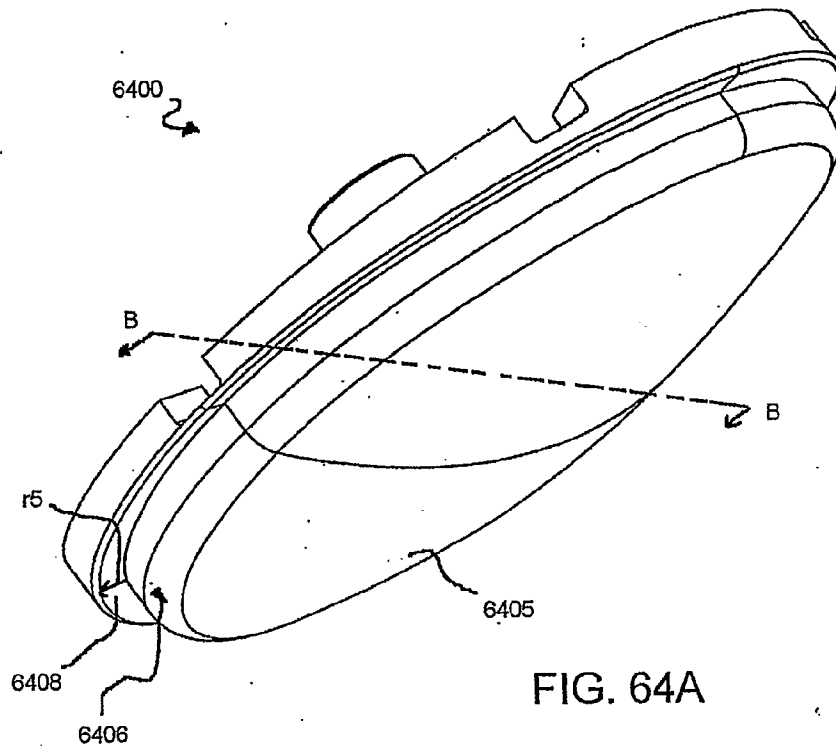

FIG. 64A

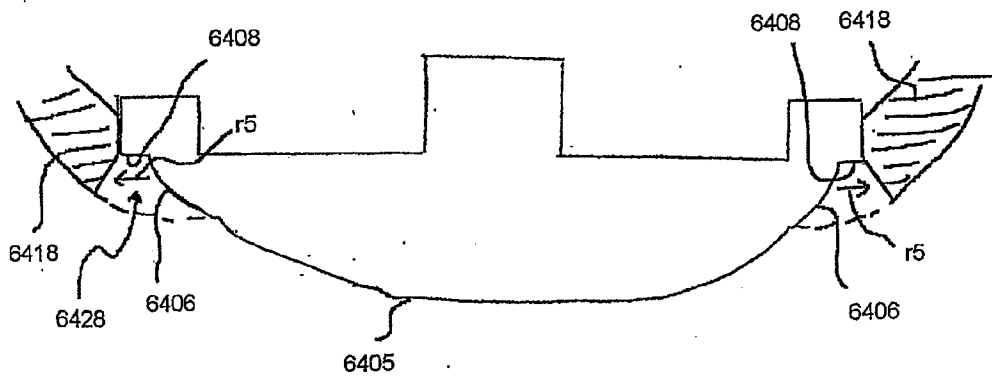

FIG. 64B

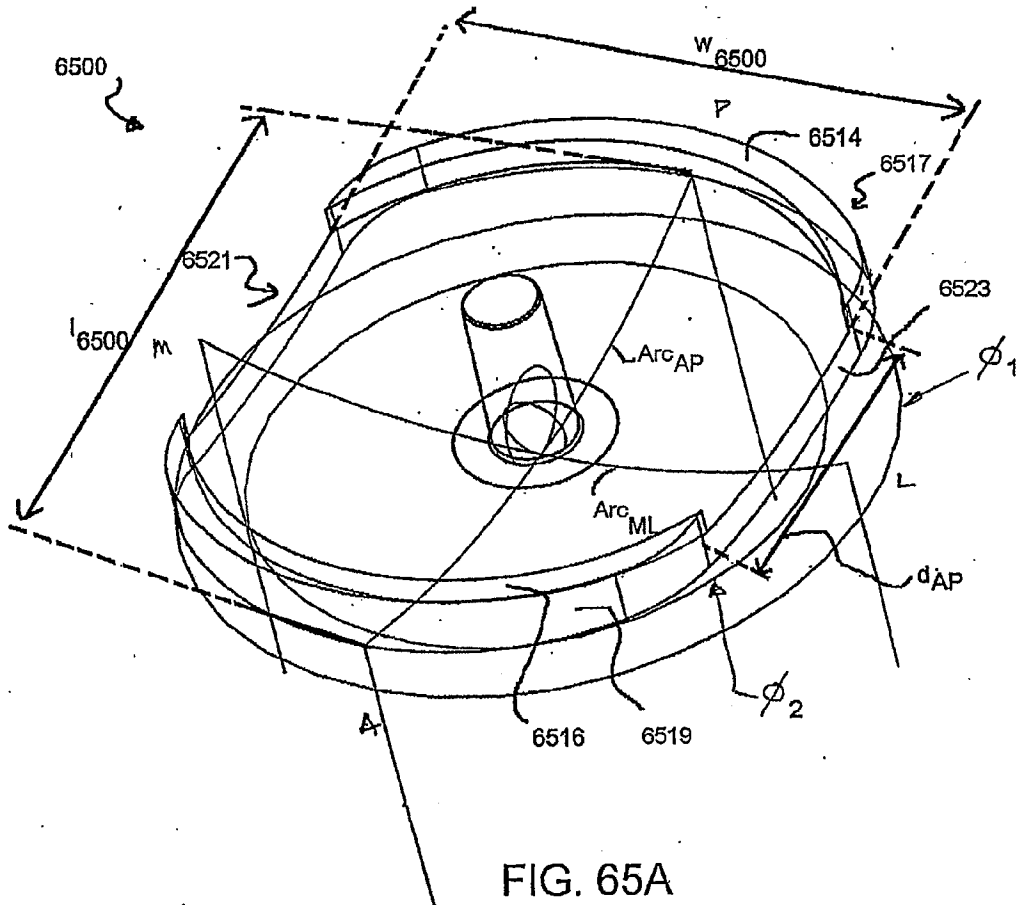

FIG. 65A

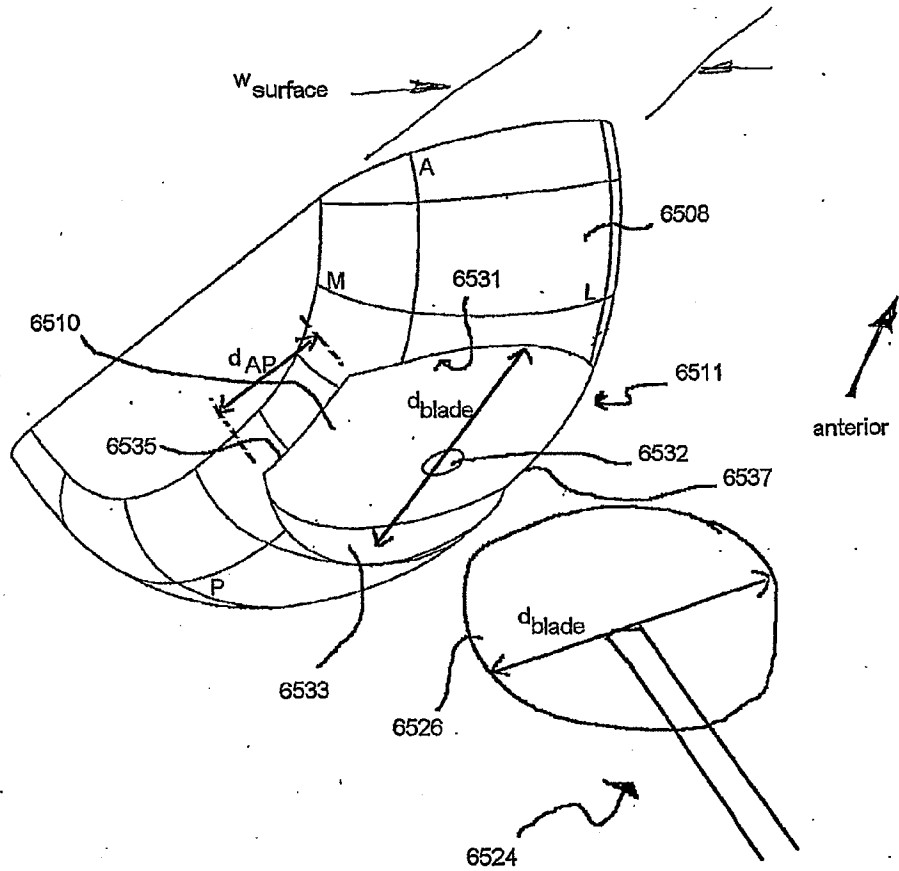

FIG. 65B

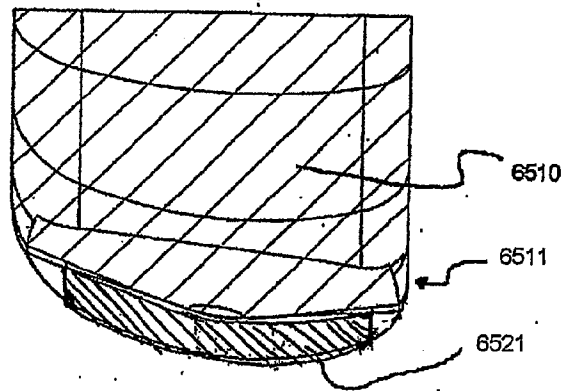

FIG. 65C

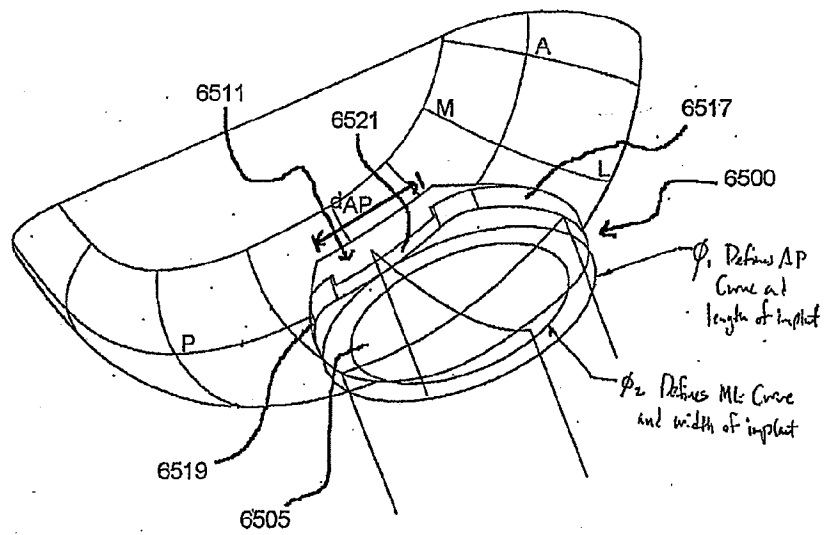

FIG. 65D

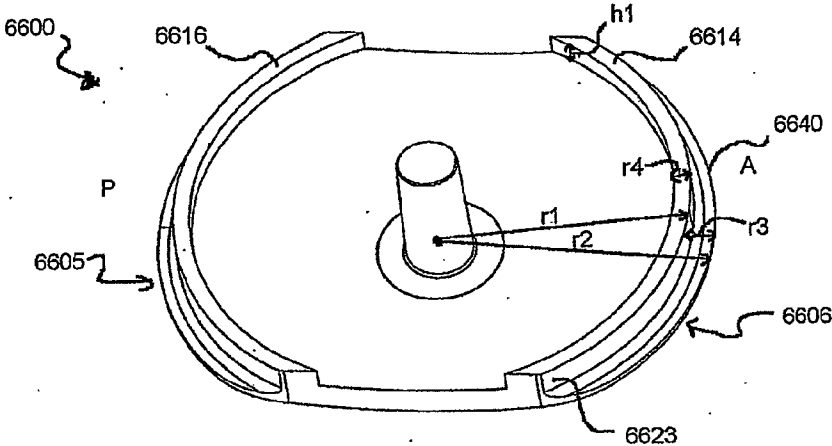

FIG. 66A

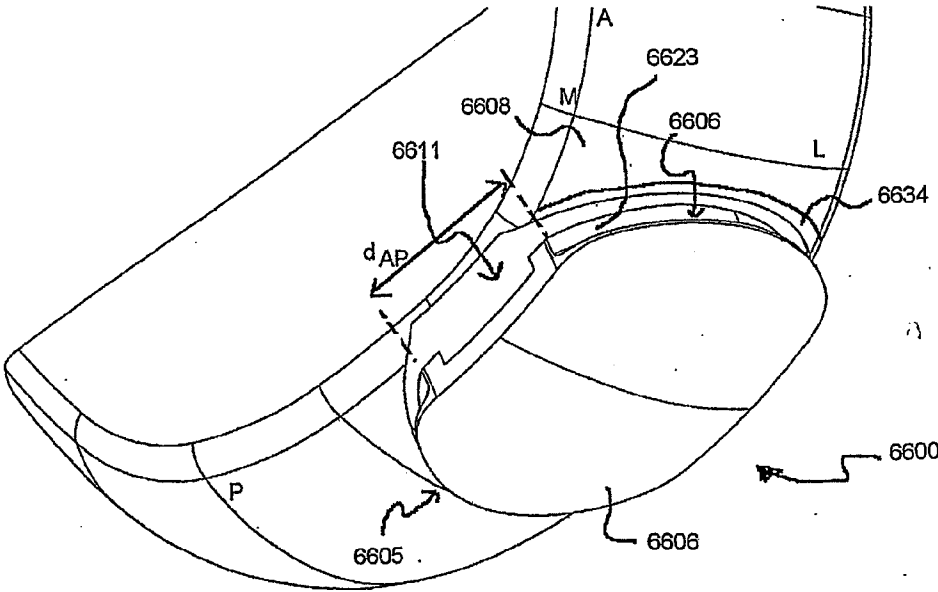

FIG. 66B

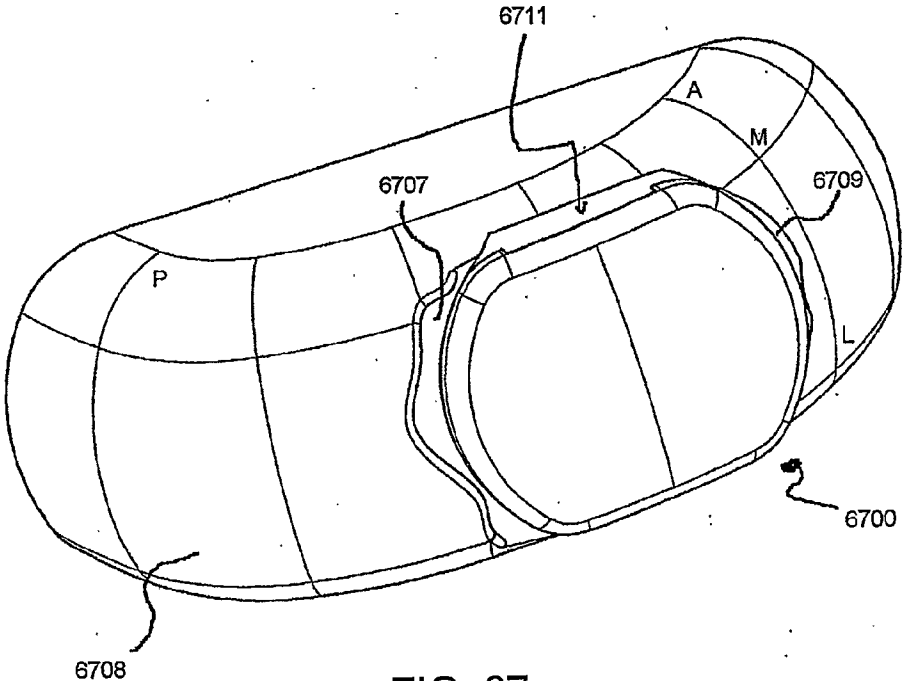

FIG. 67

(12) INTERNATIONAL APPLICATION PUBLISHED UNDER THE PATENT COOPERATION TREATY (PCT)

(19) World Intellectual Property
Organization
International Bureau



(43) International Publication Date
26 June 2003 (26.06.2003)

PCT

(10) International Publication Number
WO 2003/051210 A3

- (51) International Patent Classification⁷: A61B 17/58, A61F 2/38
- (21) International Application Number: PCT/US2002/040310
- (22) International Filing Date: 17 December 2002 (17.12.2002)
- (25) Filing Language: English
- (26) Publication Language: English
- (30) Priority Data:
10/024,077 17 December 2001 (17.12.2001) US
10/162,533 4 June 2002 (04.06.2002) US
- (71) Applicant: ARTHROSURFACE, INCORPORATED [US/US]; 1063 Turnpike Street, Stoughton, MA 02072 (US).
- (72) Inventors: EK, Steven, W.; 49 Powder Hill Road, Bolton, MA 01740 (US). TALLARIDA, Steven, J.; 11 Victoria Lane, Mansfield, MA 02048 (US).
- (74) Agents: PFLEGER, Edmund, P. et al.; Grossman Tucker Perreault & Pfleger, PLLC, 55 South Commercial Street, Manchester, NH 03101 (US).
- (81) Designated States (*national*): AE, AG, AL, AM, AT, AU, AZ, BA, BB, BG, BR, BY, BZ, CA, CH, CN, CO, CR, CU, CZ, DE, DK, DM, DZ, EC, EE, ES, FI, GB, GD, GE, GH, GM, HR, HU, ID, IL, IN, IS, JP, KE, KG, KP, KR, KZ, LC, LK, LR, LS, LT, LU, LV, MA, MD, MG, MK, MN, MW, MX, MZ, NO, NZ, OM, PH, PL, PT, RO, RU, SC, SD, SE, SG, SK, SL, TJ, TM, TN, TR, TT, TZ, UA, UG, UZ, VC, VN, YU, ZA, ZM, ZW.
- (84) Designated States (*regional*): ARIPO patent (GH, GM, KE, LS, MW, MZ, SD, SL, SZ, TZ, UG, ZM, ZW), Eurasian patent (AM, AZ, BY, KG, KZ, MD, RU, TJ, TM), European patent (AT, BE, BG, CH, CY, CZ, DE, DK, EE, ES, FI, FR, GB, GR, IE, IT, LU, MC, NL, PT, SE, SI, SK, TR), OAPI patent (BF, BJ, CF, CG, CI, CM, GA, GN, GQ, GW, ML, MR, NE, SN, TD, TG).
- Published:
— with international search report

[Continued on next page]

(54) Title: SYSTEM AND METHOD FOR JOINT RESURFACE REPAIR

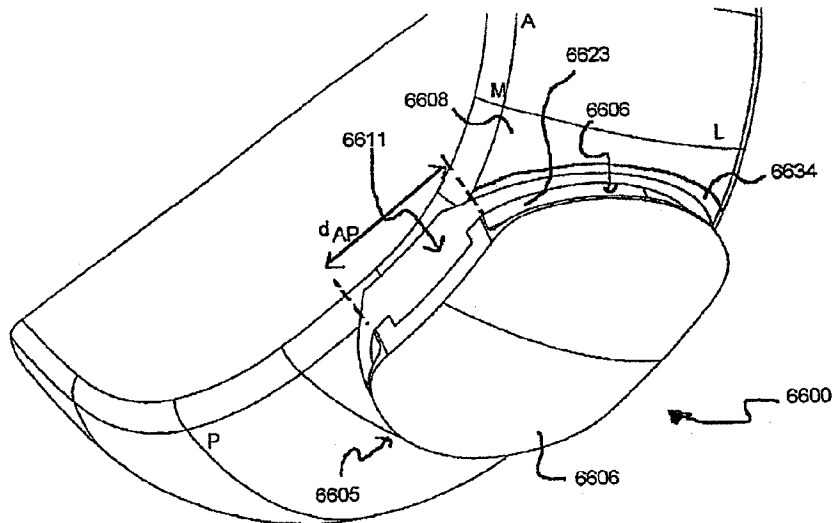

(57) Abstract: An implant (40) for installation into a portion of an articular surface (50) includes a protrusion (45) configured to cover and un-excised portion of articular surface proximate to the implant (40). Another implant may form a cavity to allow the un-excised portion of articular surface to remodel over a perimeter edge of the implant. The implant (40) may also include indentations (6805) such as grooves (6807) to promote articular cartilage remodeling over a portion of the load bearing surface of the implant (40). An elongated or non-round implant (6600) is also provided having two opposing concentric arcuate shaped sides (6611, 6612), as well as a method to seat such an implant in an articular surface. A method for seating an implant without cutting articular cartilage is also provided.

WO 2003/051210 A3



(88) Date of publication of the international search report:
25 March 2004

For two-letter codes and other abbreviations, refer to the "Guidance Notes on Codes and Abbreviations" appearing at the beginning of each regular issue of the PCT Gazette.

INTERNATIONAL SEARCH REPORT

International application No.
PCT/US02/40310

A. CLASSIFICATION OF SUBJECT MATTER IPC(7) : A61B 17/58; A61F 2/38 US CL : 606/96,99,102,104; 623/20.14 According to International Patent Classification (IPC) or to both national classification and IPC		
B. FIELDS SEARCHED Minimum documentation searched (classification system followed by classification symbols) U.S. : 606/96,99,102,104, 69; 623/20.14, 20.19, 20.21, 20.32, 20.35,20.38 Documentation searched other than minimum documentation to the extent that such documents are included in the fields searched Electronic data base consulted during the international search (name of data base and, where practicable, search terms used)		
C. DOCUMENTS CONSIDERED TO BE RELEVANT		
Category*	Citation of document, with indication, where appropriate, of the relevant passages	Relevant to claim No.
X	US 6,081,741 A (Hollis) 27 June 2000, see entire document.	1-3,13
X	US 4,158,894 A (Worrell) 26 June 1979, see entire document.	4-7,14-21
X	US 5,580,353 A (Mendes et al) 03 December 1996, see entire document.	14,15
X	US 4,531,517 A (Forte et al.) 30 July 1985, see entire document.	8,10
X	US 5,702,401 A (Shaffer) 30 December 1997, see entire document.	11
A	US 6,206,885 B1 (Ghahremani et al.) 27 March 2001, see entire document.	1-21
<input checked="" type="checkbox"/> Further documents are listed in the continuation of Box C. <input type="checkbox"/> See patent family annex.		
* Special categories of cited documents	"T" Later document published after the international filing date or priority date and not in conflict with the application but cited to understand the principle or theory underlying the invention	
"A" document defining the general state of the art which is not considered to be of particular relevance	"X" document of particular relevance; the claimed invention cannot be considered novel or cannot be considered to involve an inventive step when the document is taken alone	
"E" earlier document published on or after the international filing date	"Y" document of particular relevance; the claimed invention cannot be considered to involve an inventive step when the document is combined with one or more other such documents, such combination being obvious to a person skilled in the art	
"L" document which may throw doubts on priority claim(s) or which is cited to establish the publication date of another citation or other special reason (as specified)	"G" document member of the same patent family	
"O" document referring to an oral disclosure, use, exhibition or other means		
"P" document published prior to the international filing date but later than the priority date claimed		
Date of the actual completion of the international search 27 MARCH 2003	Date of mailing of the international search report 23 MAY 2003	
Name and mailing address of the ISA/US Commissioner of Patents and Trademarks Box PCT Washington, D.C. 20251 Facsimile No. (703) 805-9230	Authorized officer PEDRO PHILOGENE <i>Diane Smith</i> Telephone No. (703) 808-2252	

INTERNATIONAL SEARCH REPORT

International application No.
PCT/US02/40810

C (Continuation). DOCUMENTS CONSIDERED TO BE RELEVANT

Category*	Citation of document, with indication, where appropriate, of the relevant passages	Relevant to claim No.
A, P	US 6,478,801 B1 (Ralph et al.) 12 November 2002, see entire document.	1-21